



SOR BLOCK DIAGRAM

2. BLOCK DIAGRAM OVERVIEW
3. INPUTS - WIRELESS 1/2
4. INPUTS - WIRELESS 2/2
5. INPUTS - FOH
6. INPUTS - VOMS
7. INPUTS - COM/MISC
8. OUTPUTS - MAIN ARRAYS
9. OUTPUTS - DELAYS
10. OUTPUTS - VIP/FRONT FILLS
11. OUTPUTS - SUB ARRAY/VOM
12. OUTPUTS - MONITORING - ONSTAGE
13. OUTPUTS - MONITORING - BACKSTAGE
14. OUTPUTS - SURROUNDS
15. OUTPUTS - FOH
16. OUTPUTS - COM/MISC
17. OUTPUTS - IEMS
18. AXIENT ANTENNA DISTRIBUTION
19. IEM ANTENNA DISTRIBUTION
20. COM ANTENNA DISTRIBUTION - RX
21. COM ANTENNA DISTRIBUTION - TX
22. CONTROL NETWORK
23. DANTE NETWORK
24. AVB NETWORK
25. TWINLANe
26. MIDI/TIMECODE
27. COM DIAGRAM - WIRED - BOOTH
28. COM DIAGRAM - WIRED - CATWALK
29. COM DIAGRAM - WIRELESS

SHOW

SCHOOL OF
ROCK

VENUE

YOUNG LIVING
CENTRE STAGE

DEPARTMENT HEAD

MICHELLE OHUMUKINI
michelleo@hct.org

DRAFTED BY

MATTHEW KUPFERER

NOTES

TITLE

TABLE
OF
CONTENTS

SHEET

BLOCK DIAGRAM

1

29

LAST UPDATED

Nov 2, 2022

SCALE

NO SCALE



SCHOOL OF ROCK

YOUNG LIVING CENTRE STAGE

DEPARTMENT HEAD
MICHELLE OHUMUKINI
michelleo@hct.org

DRAFTED BY
MATTHEW KUPFERER

NOTES
- CORRESPONDING FILE:
'CS Speaker Plot'

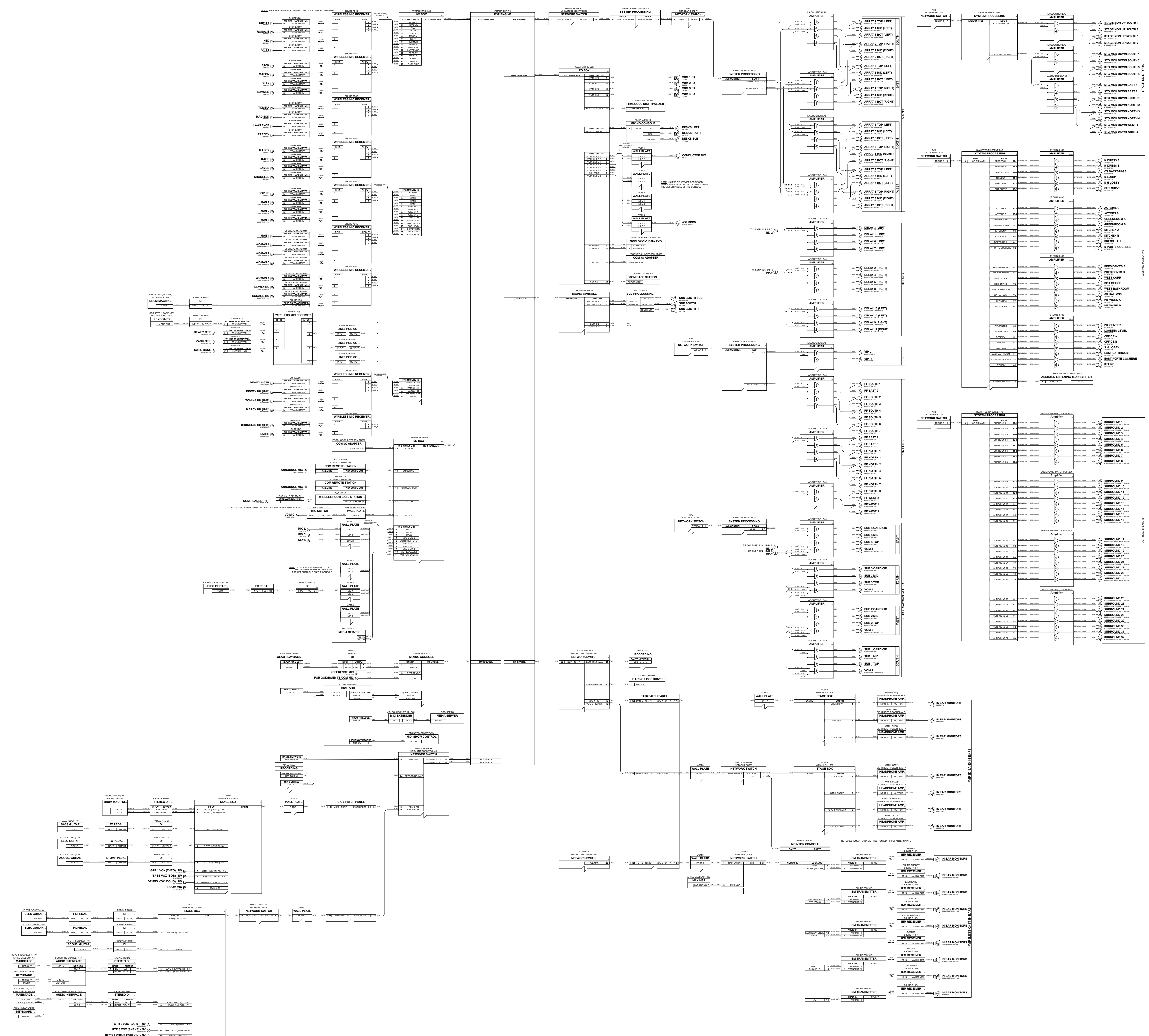

TITLE BLOCK DIAGRAM OVERVIEW

SHEET BLOCK DIAGRAM

2

29

AMP ROOM

NOTE: SEE AXIENT ANTENNA DISTRIBUTION (BD-18) FOR ANTENNA INFO

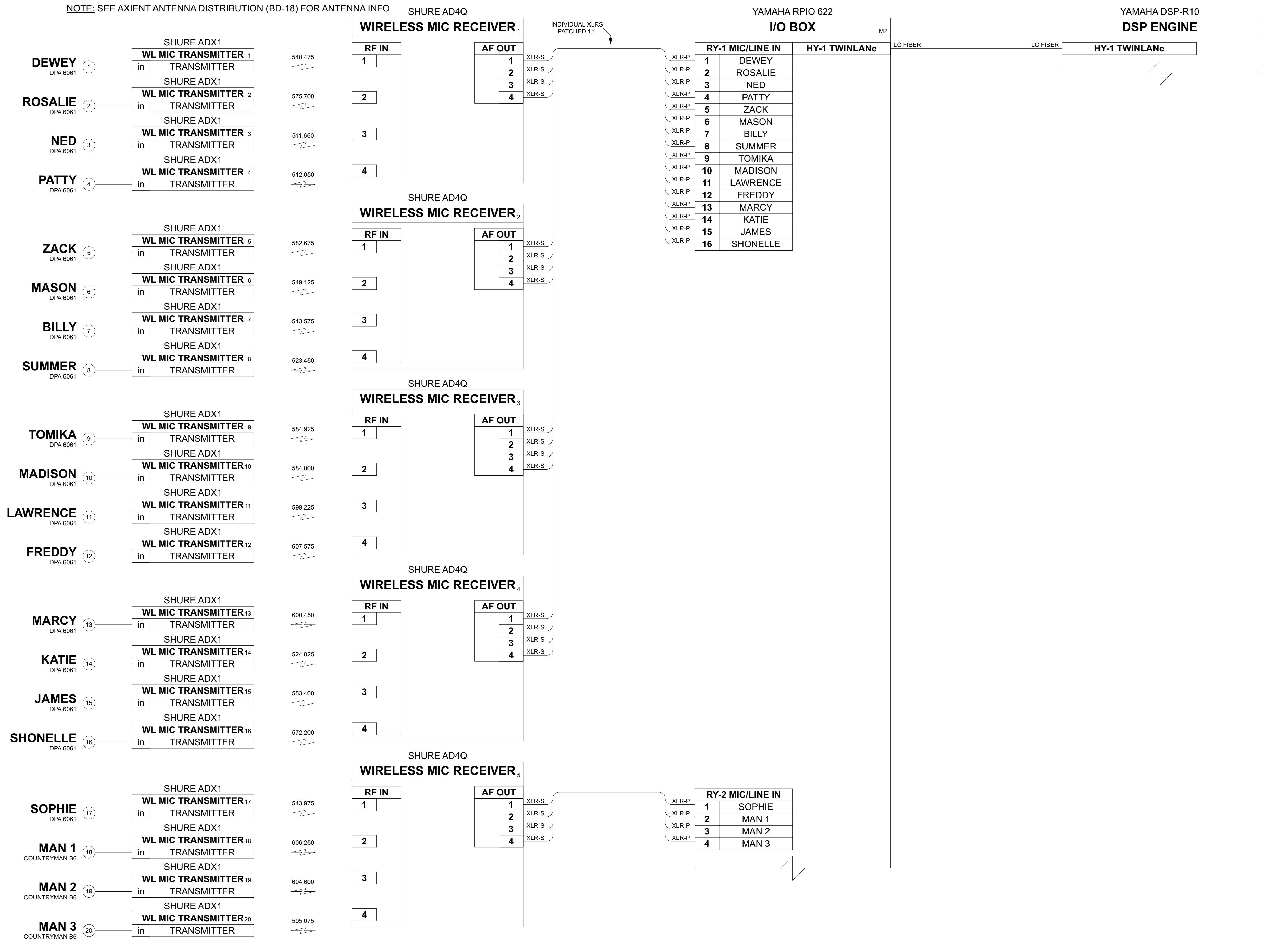

AMP ROOM

NOTE: SEE AXIENT ANTENNA DISTRIBUTION (BD-18) FOR ANTENNA INFO

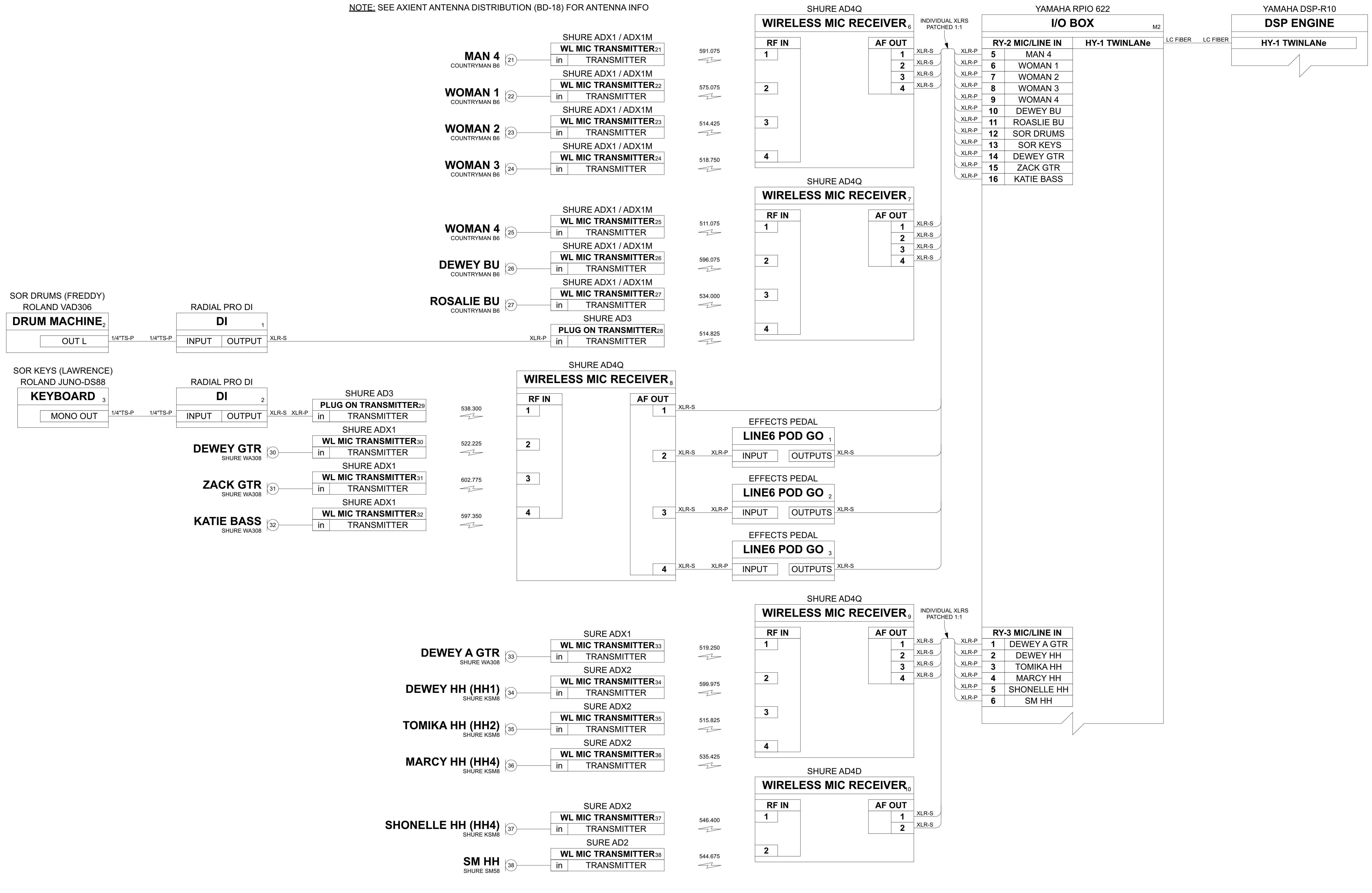

SHOW
SCHOOL OF ROCK

VENUE
YOUNG LIVING CENTRE STAGE

DEPARTMENT HEAD
MICHELLE OHUMUKINI
michelleo@hct.org

DRAFTED BY
MATTHEW KUPFERER

NOTES

TITLE
INPUTS WIRELESS 2/2

SHEET
BLOCK DIAGRAM

4
29

LAST UPDATED
Nov 2, 2022 SCALE
NO SCALE

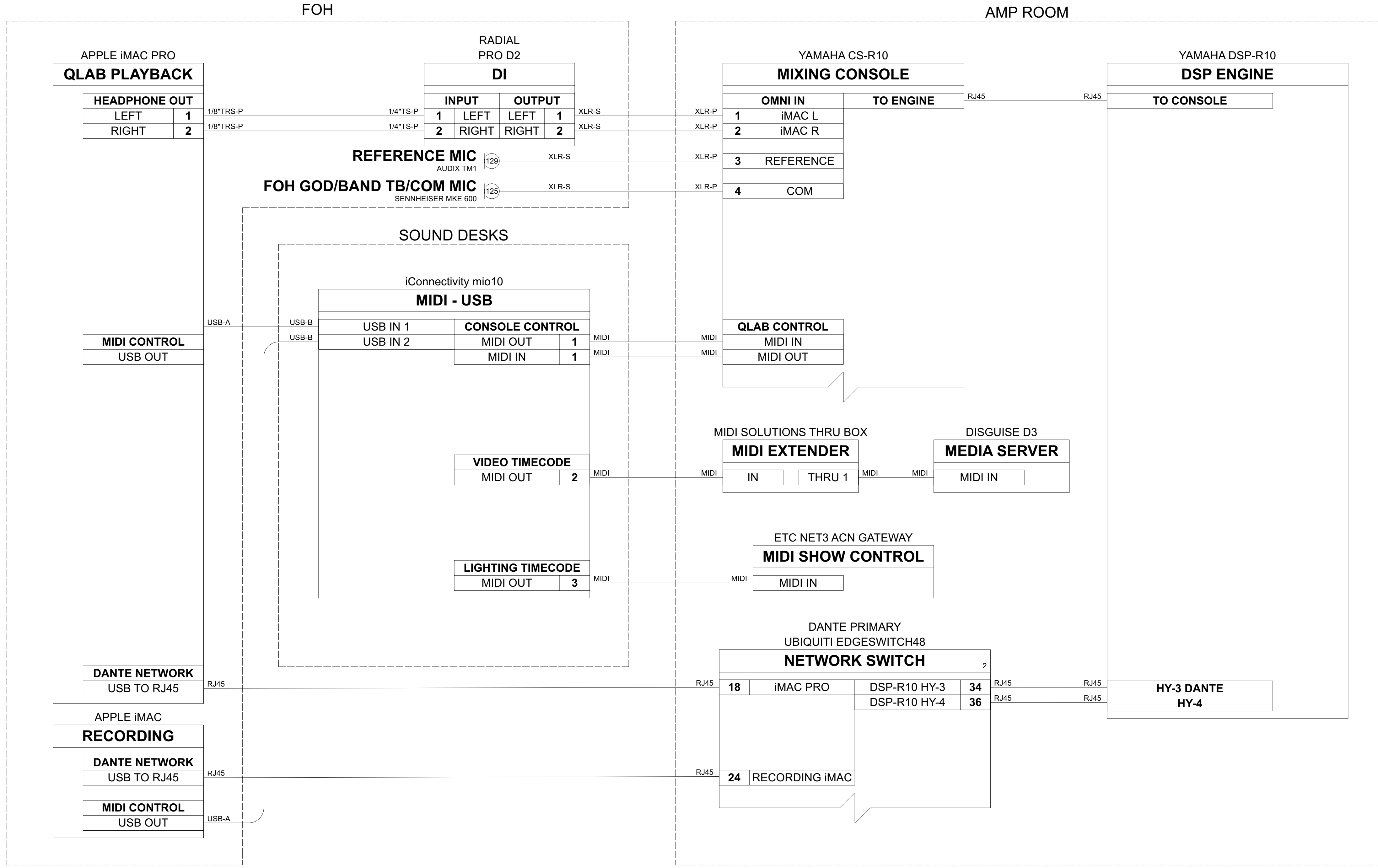

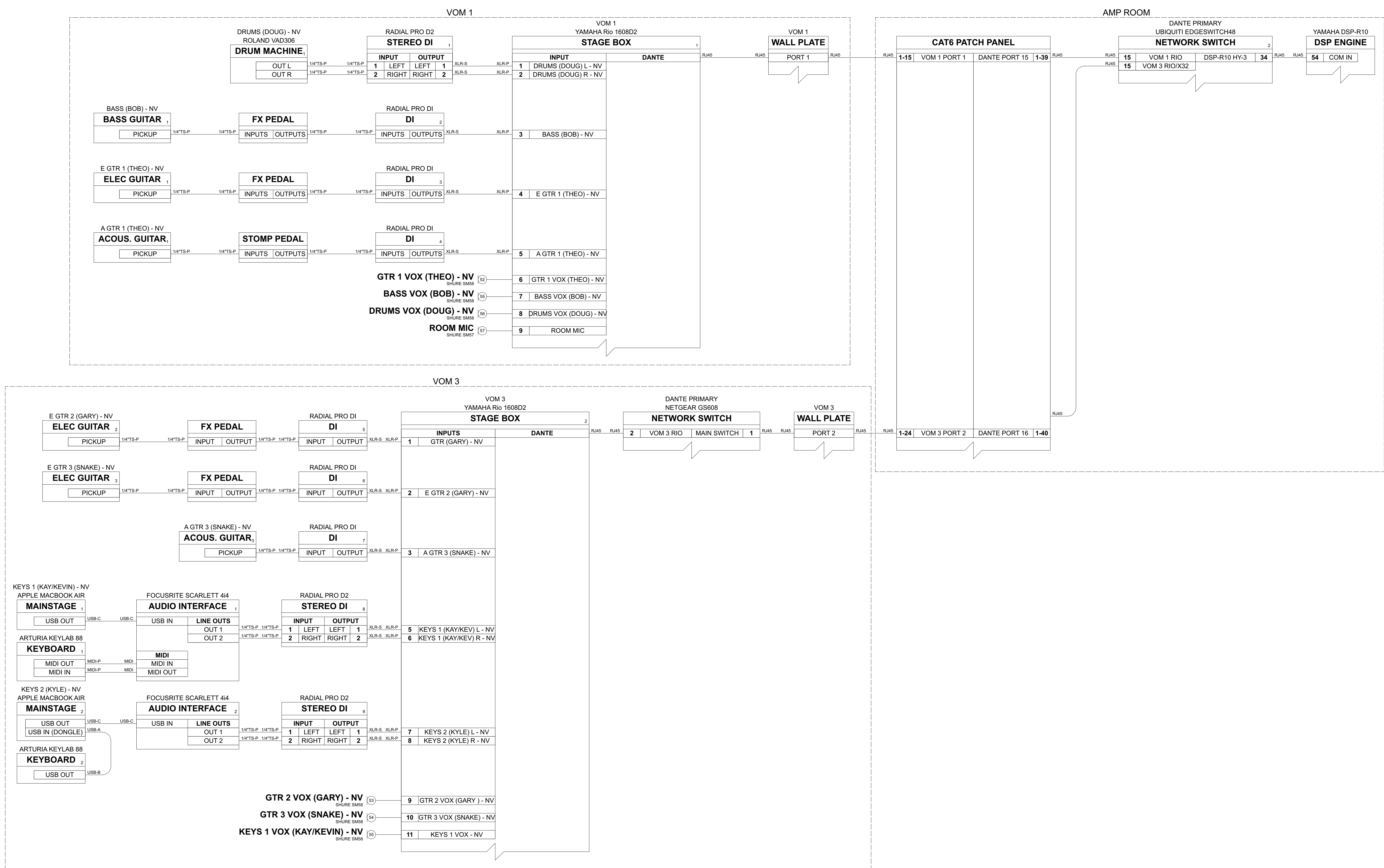

AMP ROOM

PRODUCTION INTERCOM AD903
COM I/O ADAPTER
4-PIN PINS 3/4

YAMAHA RPIO 622
I/O BOX M2

RY-5 MIC/LINE IN	HY-TWINLANe
12 COM IN	
13 SM CORNER	
14 SM CLEARCOM	
16 VO MIC	
15 RAD SM	
RY-6 MIC/LINE IN	
1 MIC L	
2 MIC R	
3 KEYS	
4 VOM 2 MIC 2	
5 EGTR 3 (OFFSTG)	
6 VOM 3 MIC 2	
7 VOM 4 MIC 1	
8 VOM 4 MIC 2	
10 VID PLAYBACK L	
11 VID PLAYBACK R	

YAMAHA DSP-R10
DSP ENGINE
HY-1 TWINLANe

SM CORNER
SM CORNER CLEAR-COM RM-704
COM REMOTE STATION
ANNOUNCE MIC CLEARCOM GM-9 (130)
PANEL MIC ANNOUNCE OUT XLR-S

SM BOOTH
SM BOOTH CLEAR-COM RM-704
COM REMOTE STATION
ANNOUNCE MIC CLEARCOM GM-9 (131)
PANEL MIC ANNOUNCE OUT XLR-S
ROLLS MS111 MIC SWITCH
UPPER BOOTH EAST WALL PLATE
VO MIC SHURE SM58 (133) INPUT OUTPUT XLR-S XLR-P
UBE 1 BARE WIRE

COM HEADSET RTS PH-88 (7)
RAD UV-1G BELTPACK WIRELESS BELTPACK (7)

RAD UV-1G
WIRELESS COM BASE STATION 2
STAGE ANNOUNCE XLR-S XLR-P

NOTE: SEE COM ANTENNA DISTRIBUTION - RX (BD-20) FOR ANTENNA INFO

VOMS
VOM 1 WALL PLATE
MIC L DPA 4011 (134) XLR-S XLR-P BARE WIRE
MIC R DPA 4011 (135) XLR-S XLR-P BARE WIRE
KEYS (138) XLR-S XLR-P BARE WIRE
LINE 2 BARE WIRE

NOTE: EXCEPT WHERE INDICATED, THESE PATCH PANEL INPUTS DO NOT HAVE PRE-SET CHANNELS ON THE CONSOLE

VOM 2 WALL PLATE
MIC 1 BARE WIRE
MIC 2 BARE WIRE

VOM 3 WALL PLATE
MIC 1 BARE WIRE
MIC 2 BARE WIRE

VOM 4 WALL PLATE
MIC 1 BARE WIRE
MIC 2 BARE WIRE

E GTR 3 (OFFSTAGE) - NV
ELEC GUITAR (3) PICKUP 1/4"TS-P 1/4"TS-P
FX PEDAL INPUT OUTPUT 1/4"TS-P 1/4"TS-P
RADIAL PRO DI DI (10) INPUT OUTPUT XLR-S XLR-P

DISGUISE D3
MEDIA SERVER
OUT L XLR-S

INDIVIDUAL HOUSE WIRES PATCHED 1:1

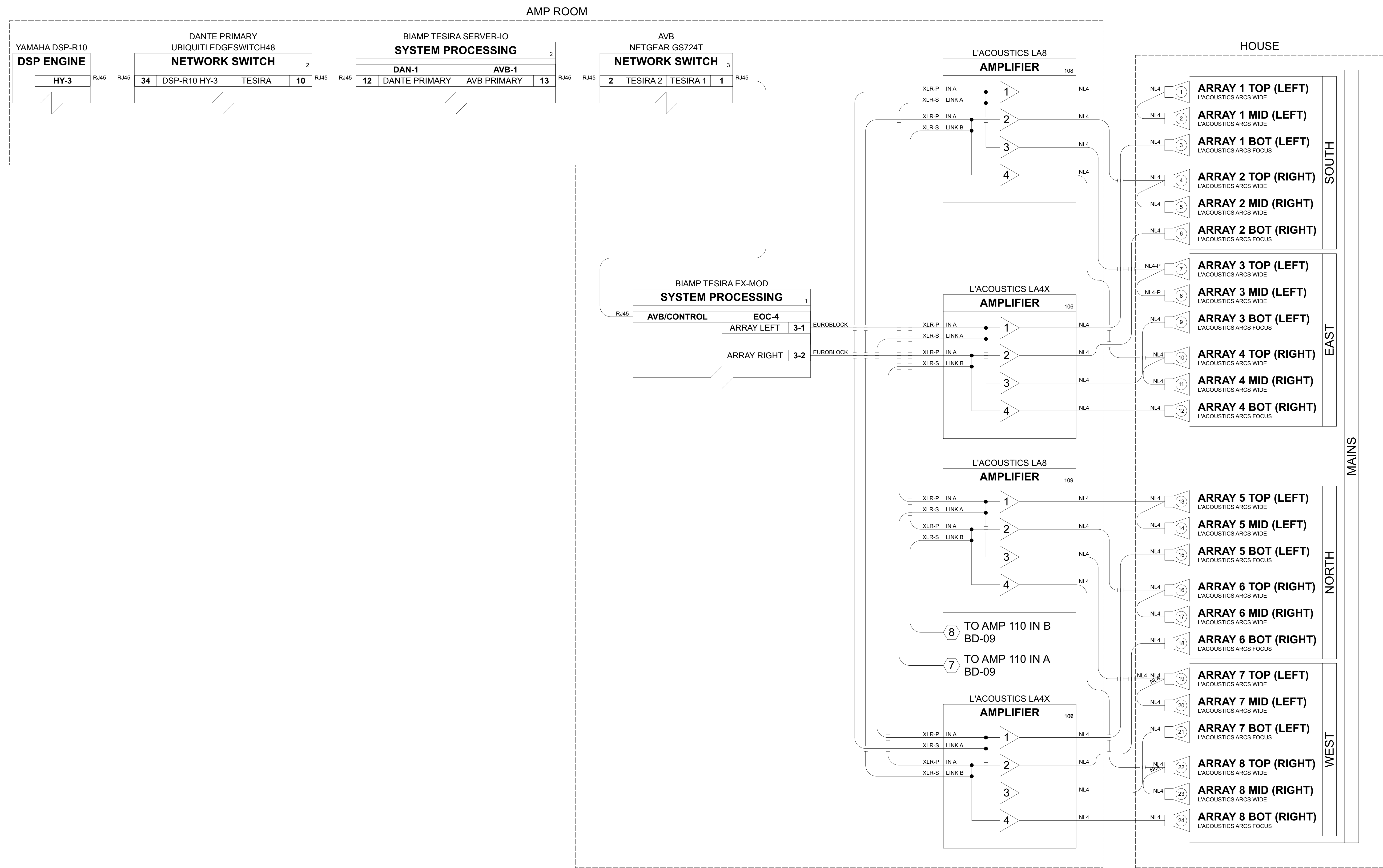



HALE CENTRE THEATRE

SHOW
**SCHOOL OF
ROCK**

VENUE
**YOUNG LIVING
CENTRE STAGE**

DEPARTMENT HEAD
MICHELLE OHUMUKINI
michelleo@hct.org

DRAFTED BY
MATTHEW KUPFERER

NOTES
- CORRESPONDING FILE:
'CS Speaker Plot'
SP-08 TO SP-13

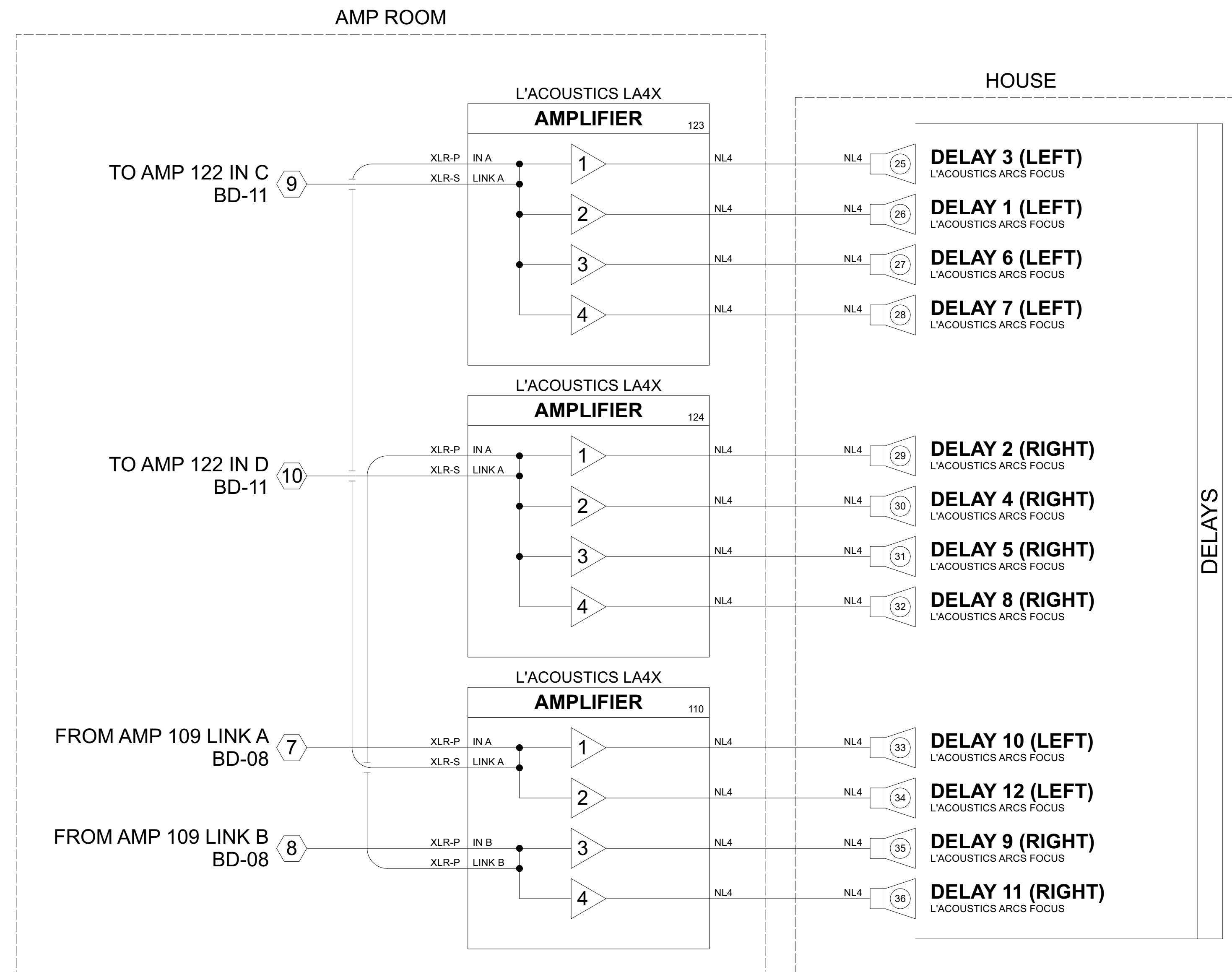

TITLE
**OUTPUTS
DELAYS**

SHEET BLOCK DIAGRAM

9
29

LAST UPDATED
Nov 2, 2022 SCALE
NO SCALE

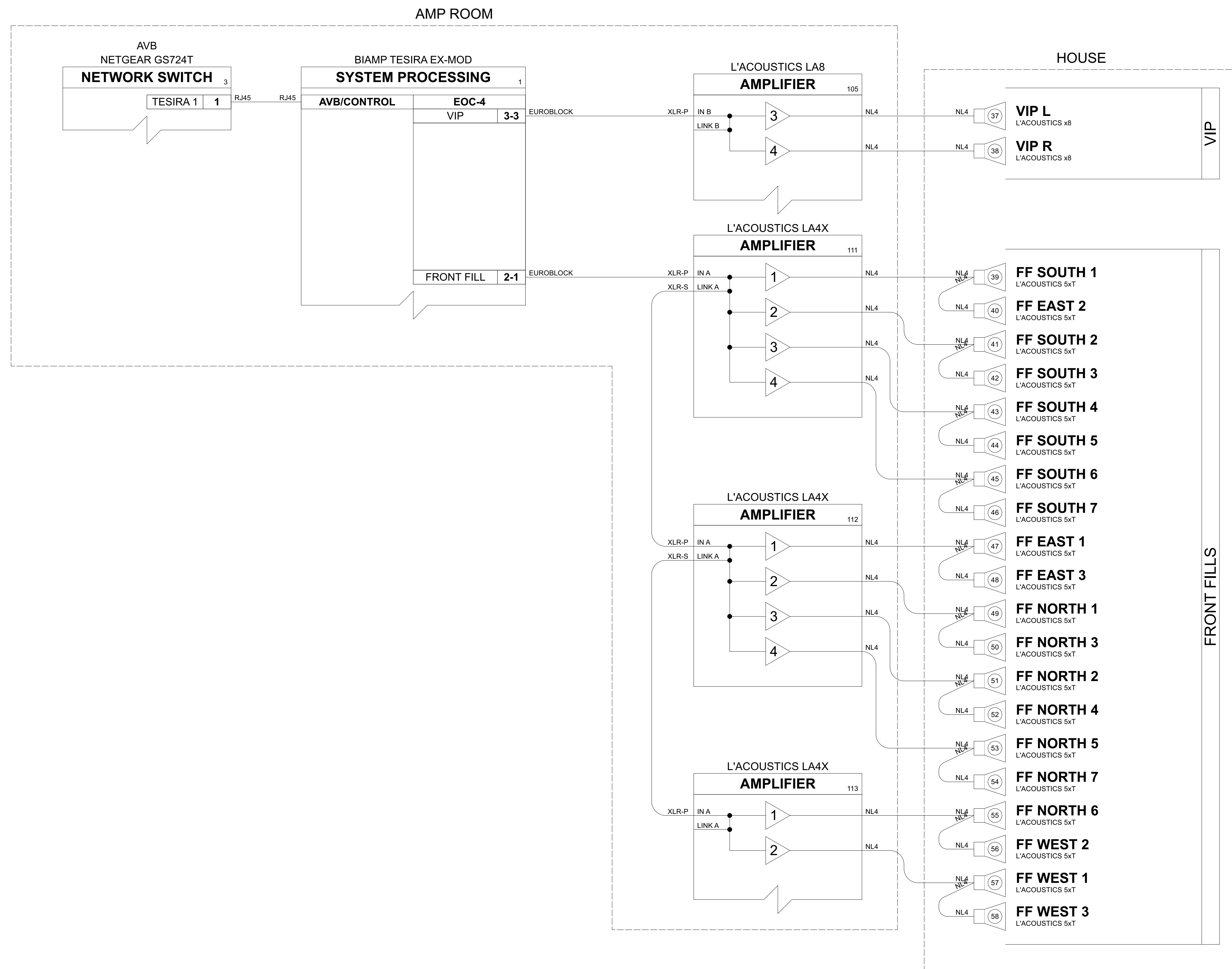

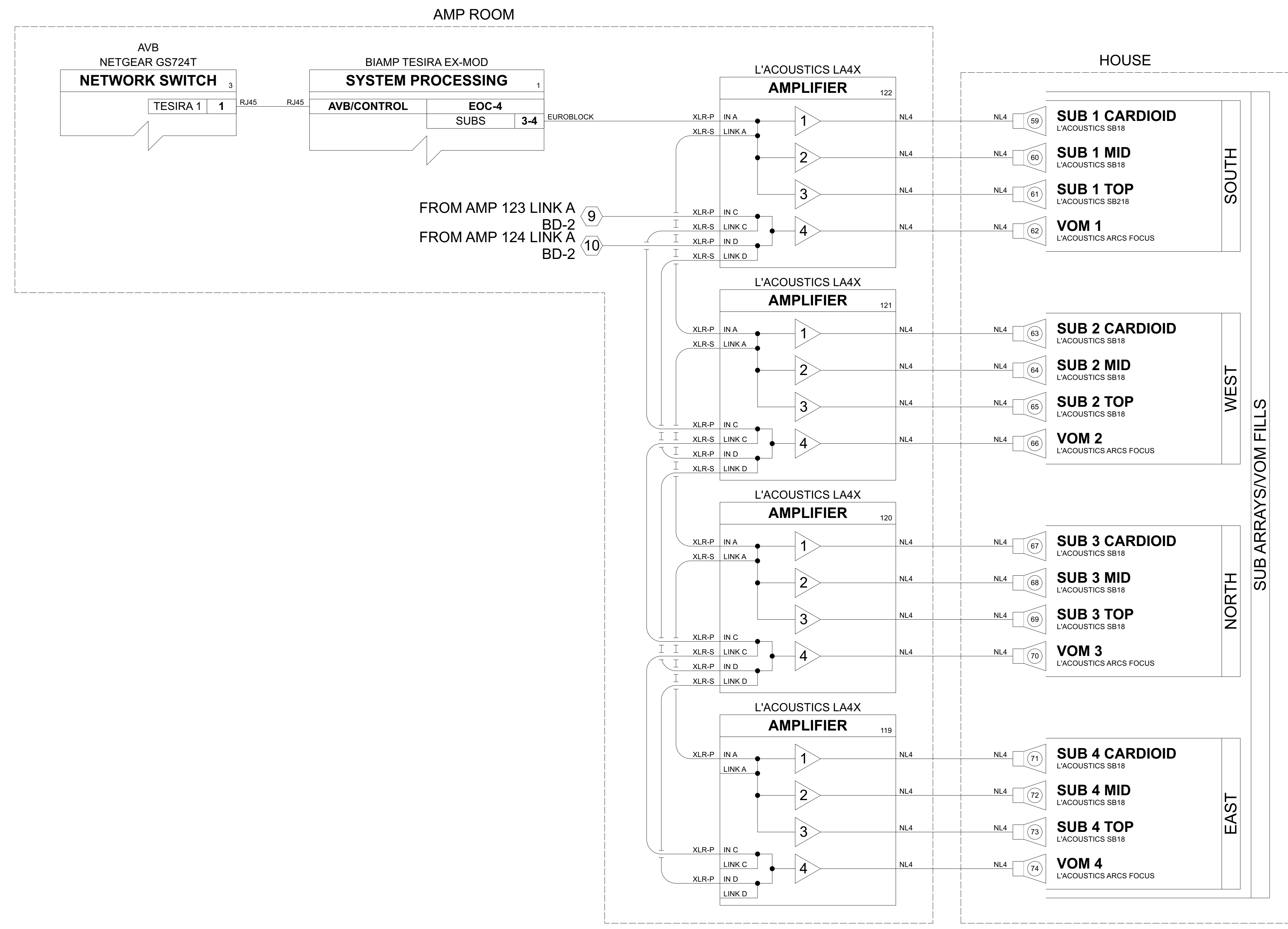

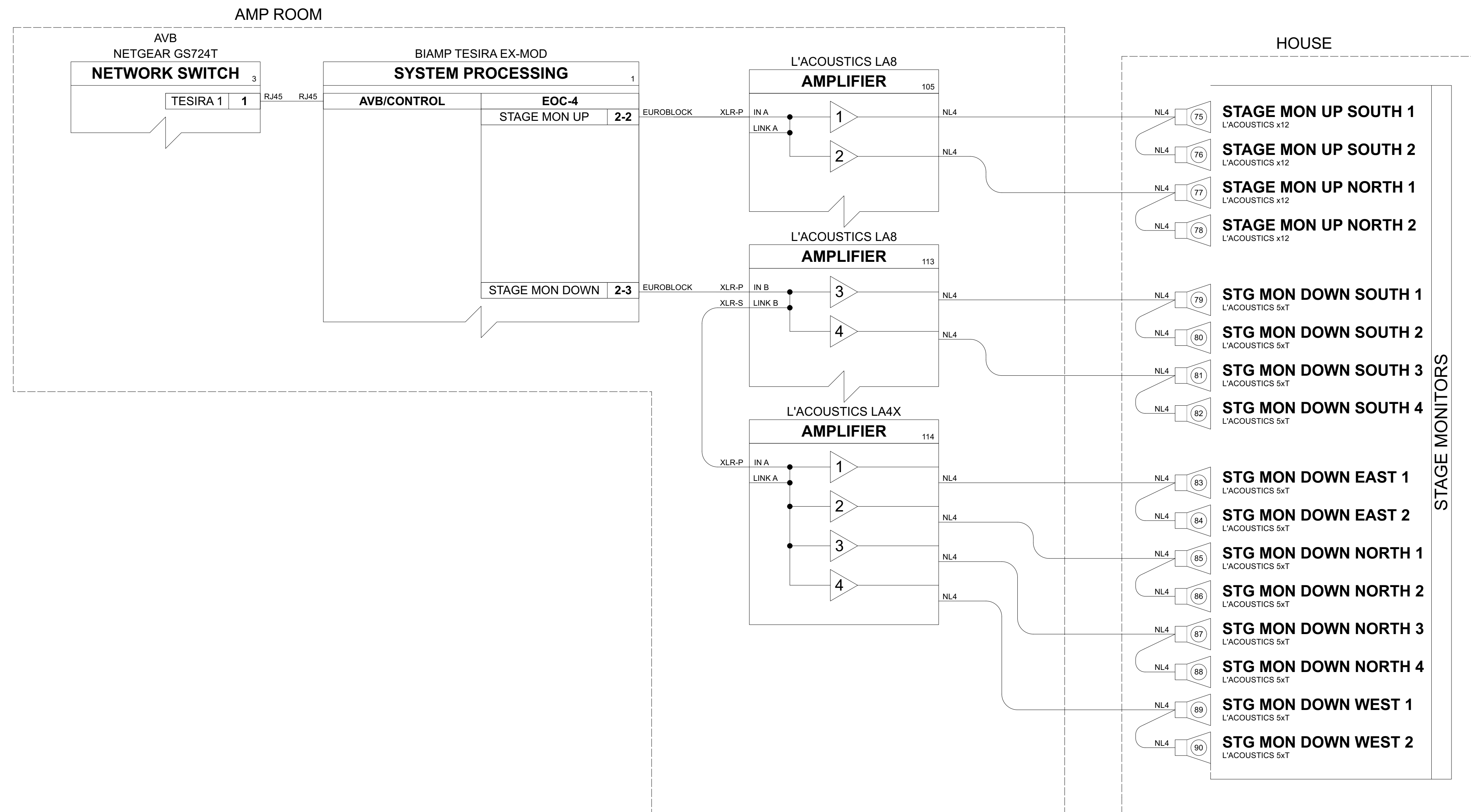

SHOW
SCHOOL OF ROCK

VENUE
YOUNG LIVING CENTRE STAGE

DEPARTMENT HEAD
MICHELLE OHUMUKINI
michelleo@hct.org

DRAFTED BY
MATTHEW KUPFERER

NOTES
- CORRESPONDING FILE:
'CS Speaker Plot'
SP-36 TO SP-47

TITLE
OUTPUTS MONITORING ONSTAGE

SHEET BLOCK DIAGRAM

12 / 29

LAST UPDATED **Nov 2, 2022** SCALE **NO SCALE**



HALE CENTRE THEATRE

SHOW
SCHOOL OF ROCK

VENUE
YOUNG LIVING CENTRE STAGE

DEPARTMENT HEAD
MICHELLE OHUMUKINI
michelleo@hct.org

DRAFTED BY
MATTHEW KUPFERER

NOTES
- CORRESPONDING FILE:
'CS Speaker Plot'
SP-36 TO SP-47

TITLE
OUTPUTS MONITORING BACKSTAGE

SHEET BLOCK DIAGRAM

13

29

LAST UPDATED
Nov 2, 2022 SCALE
NO SCALE

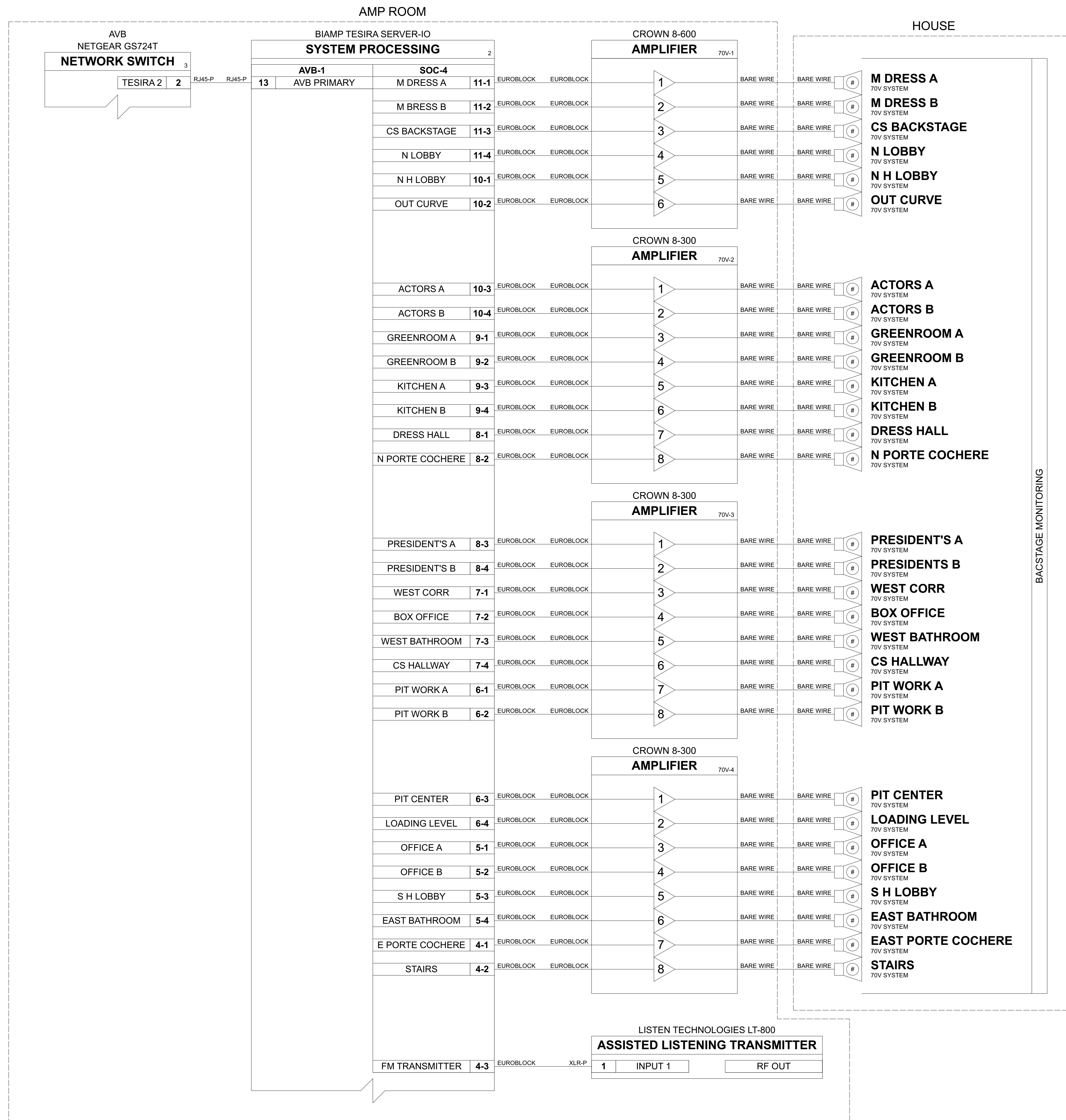



HALE CENTRE THEATRE

SHOW
SCHOOL OF ROCK

VENUE
YOUNG LIVING CENTRE STAGE

DEPARTMENT HEAD
MICHELLE OHUMUKINI
michelleo@hct.org

DRAFTED BY
MATTHEW KUPFERER

NOTES
- CORRESPONDING FILE:
'CS Speaker Plot'
SP-48 TO SP-53

TITLE
OUTPUTS SURROUNDS

SHEET BLOCK DIAGRAM

14

29

LAST UPDATED
Nov 2, 2022 SCALE
NO SCALE

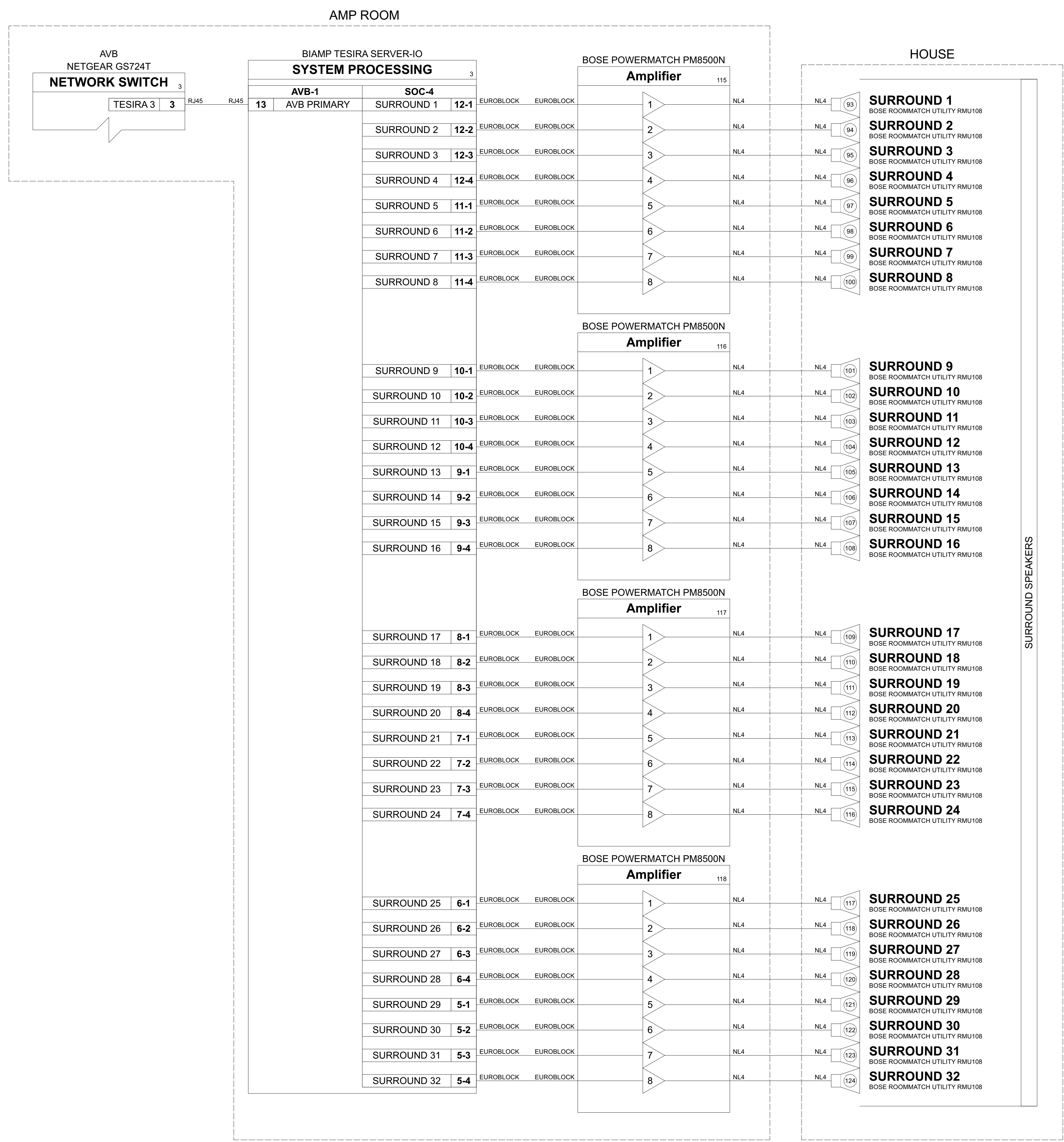

AMP ROOM

HOUSE

SURROUND SPEAKERS

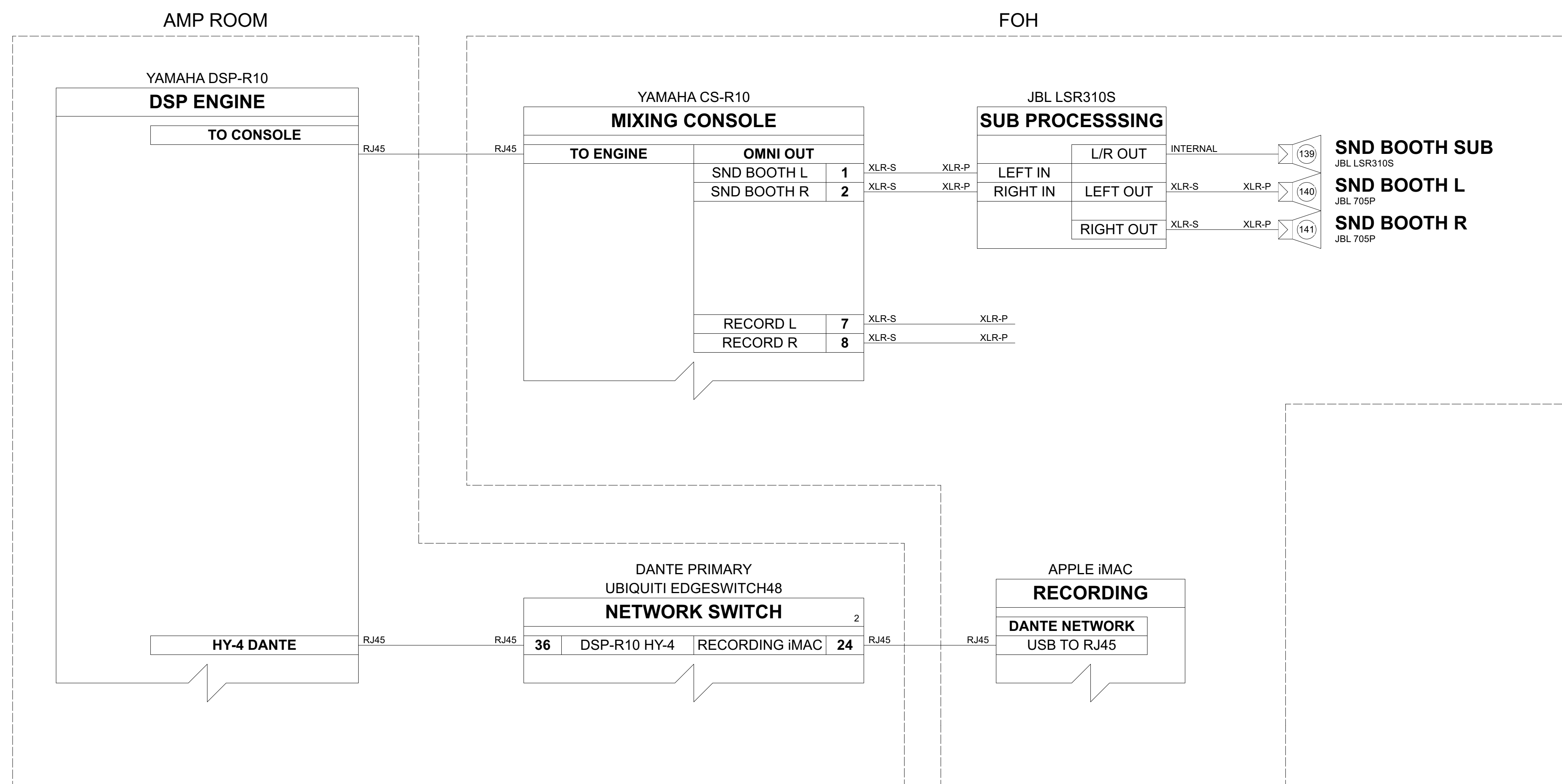

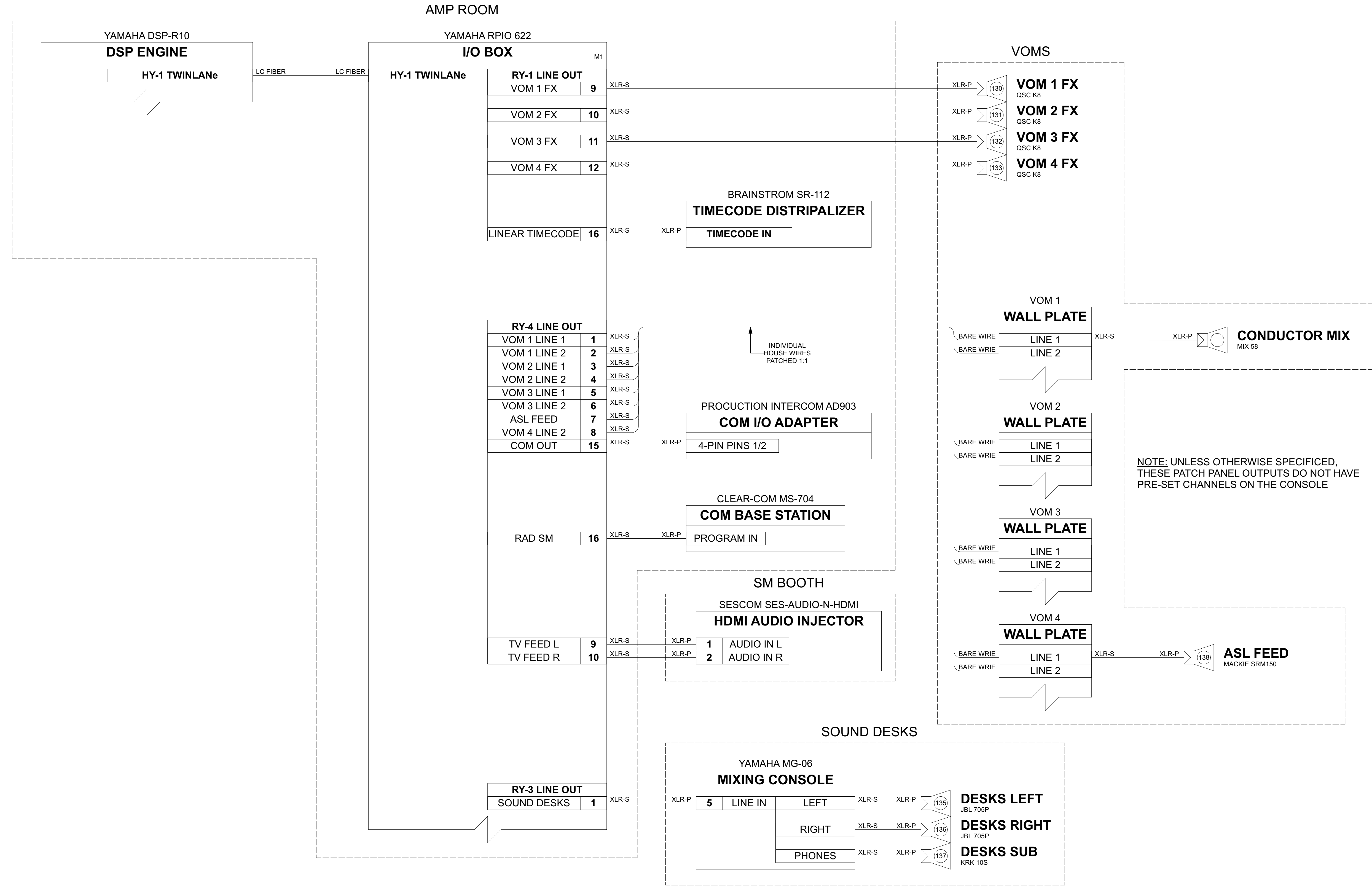



SHOW
SCHOOL OF ROCK

VENUE
YOUNG LIVING CENTRE STAGE

DEPARTMENT HEAD
MICHELLE OHUMUKINI
michelleo@hct.org

DRAFTED BY
MATTHEW KUPFERER

NOTES
- CORRESPONDING FILE:
'CS Speaker Plot'
SP-54 TO SP-59

TITLE
OUTPUTS IEMS

SHEET BLOCK DIAGRAM

17
29

LAST UPDATED
Nov 2, 2022 SCALE
NO SCALE

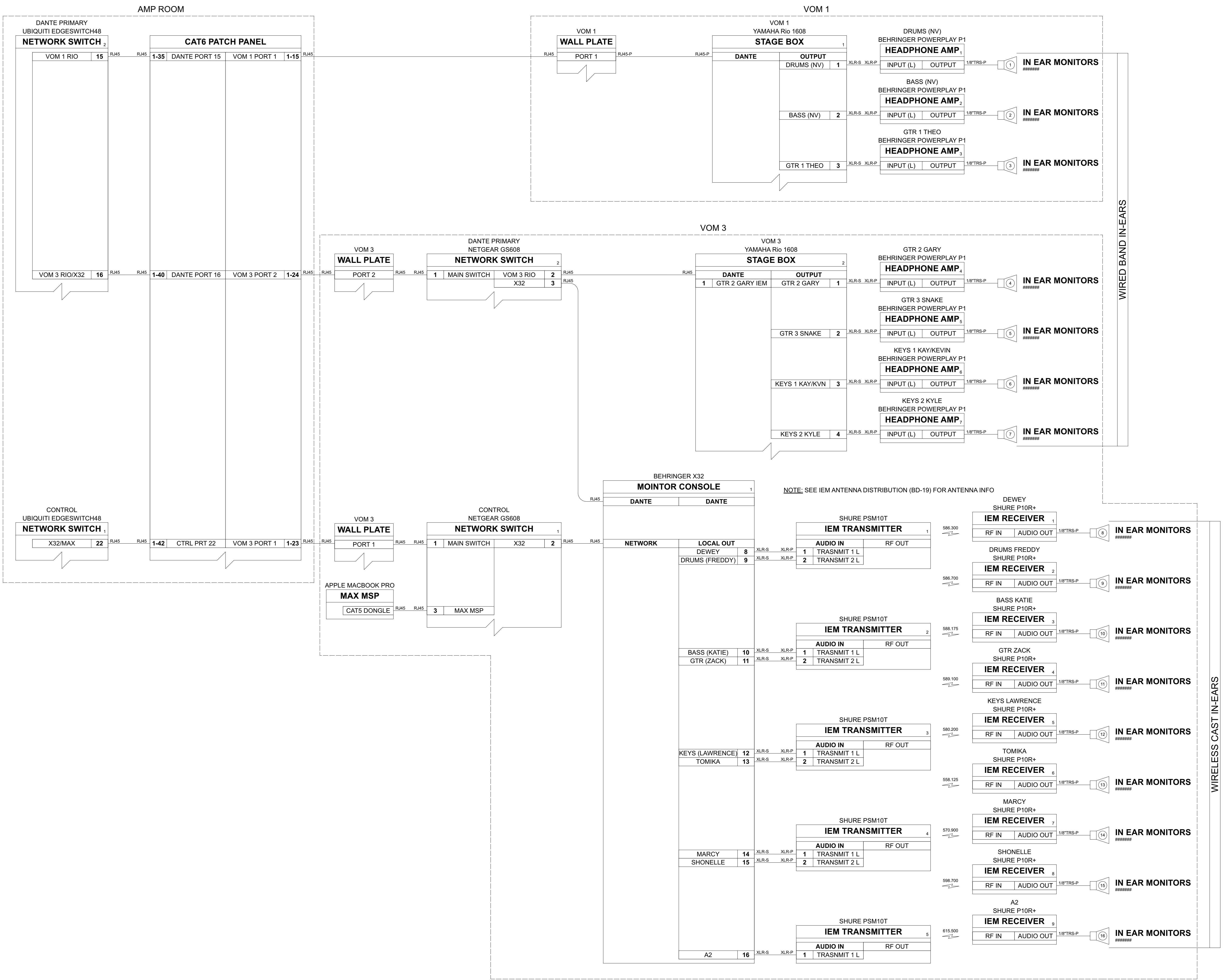

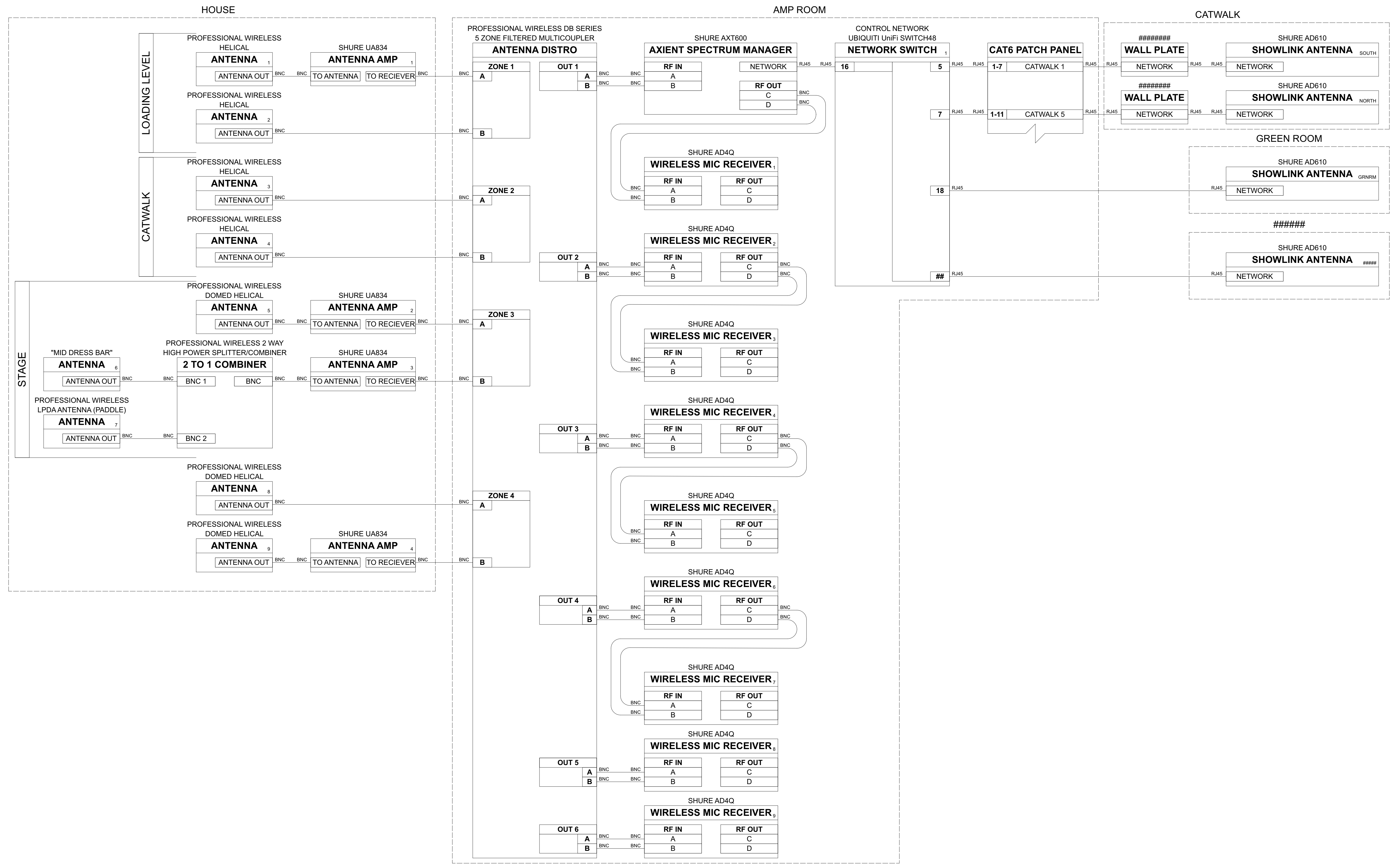

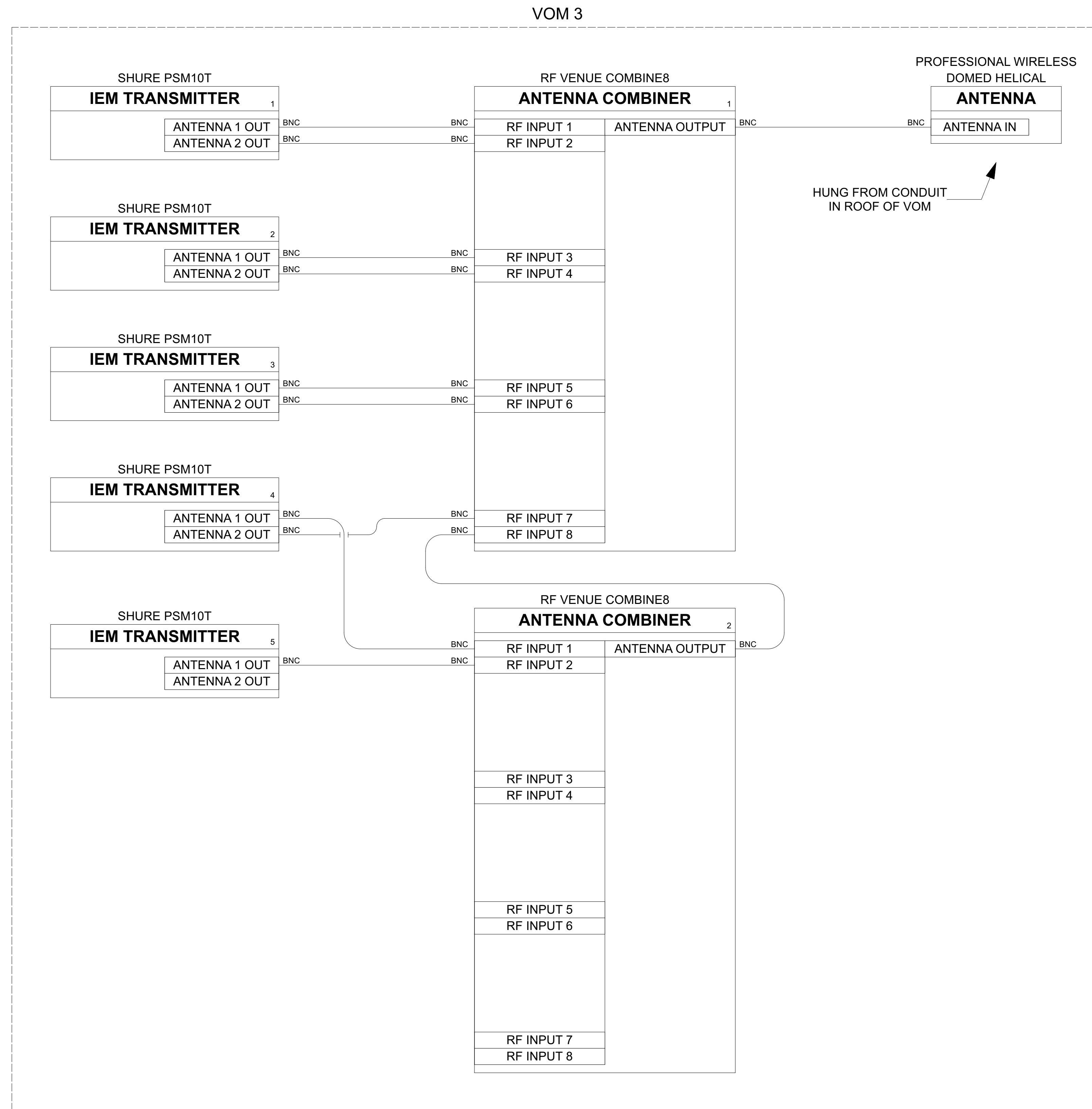

SHOW
SCHOOL OF ROCK

VENUE
YOUNG LIVING CENTRE STAGE

DEPARTMENT HEAD
MICHELLE OHUMUKINI
michelleo@hct.org

DRAFTED BY
MATTHEW KUPFERER

NOTES
- CORRESPONDING FILE:
'CS Antenna Plot'

TITLE
IEM ANTENNA DISTRIBUTION

SHEET BLOCK DIAGRAM

19

29

LAST UPDATED
Nov 2, 2022

SCALE
NO SCALE

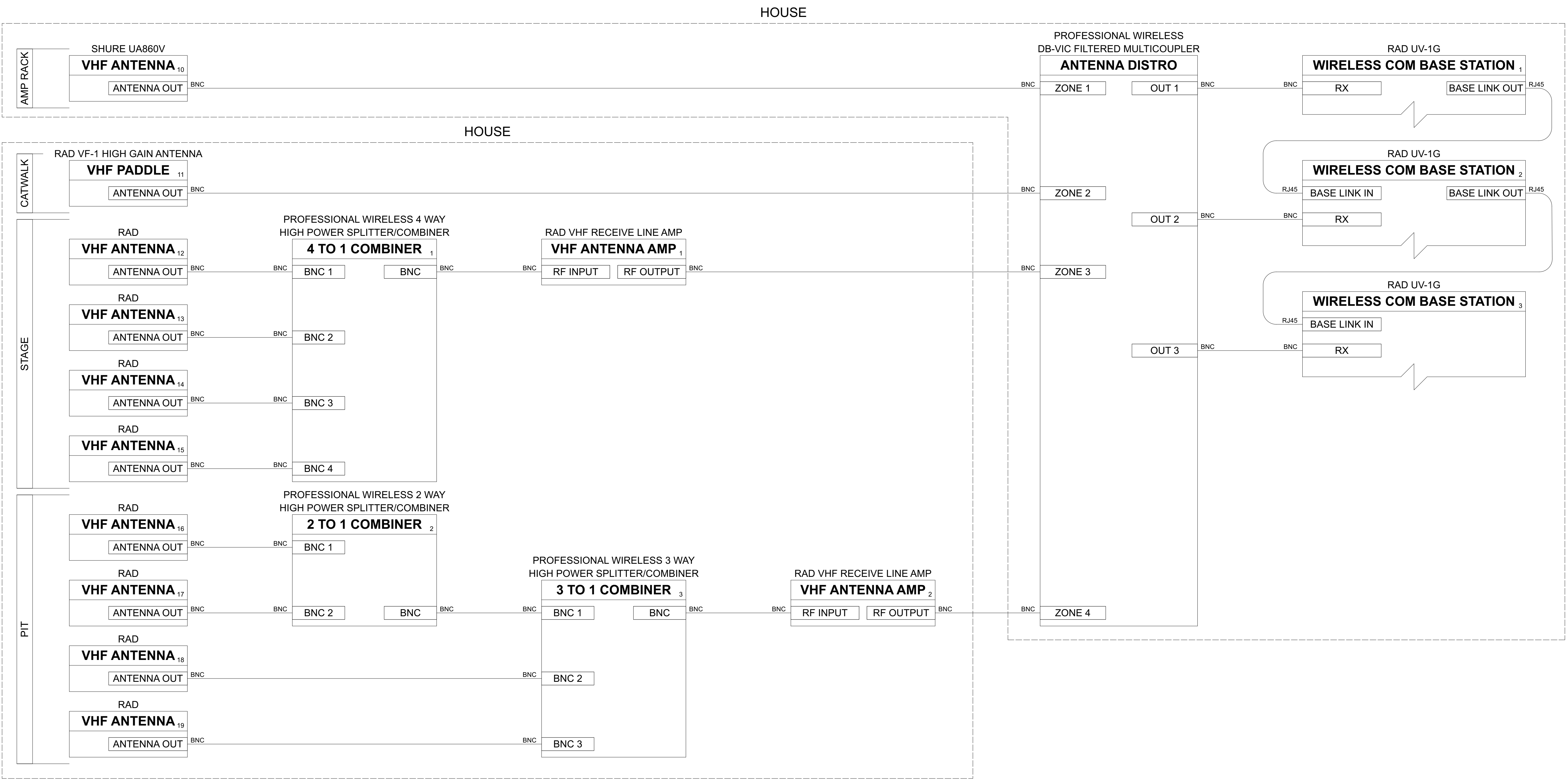

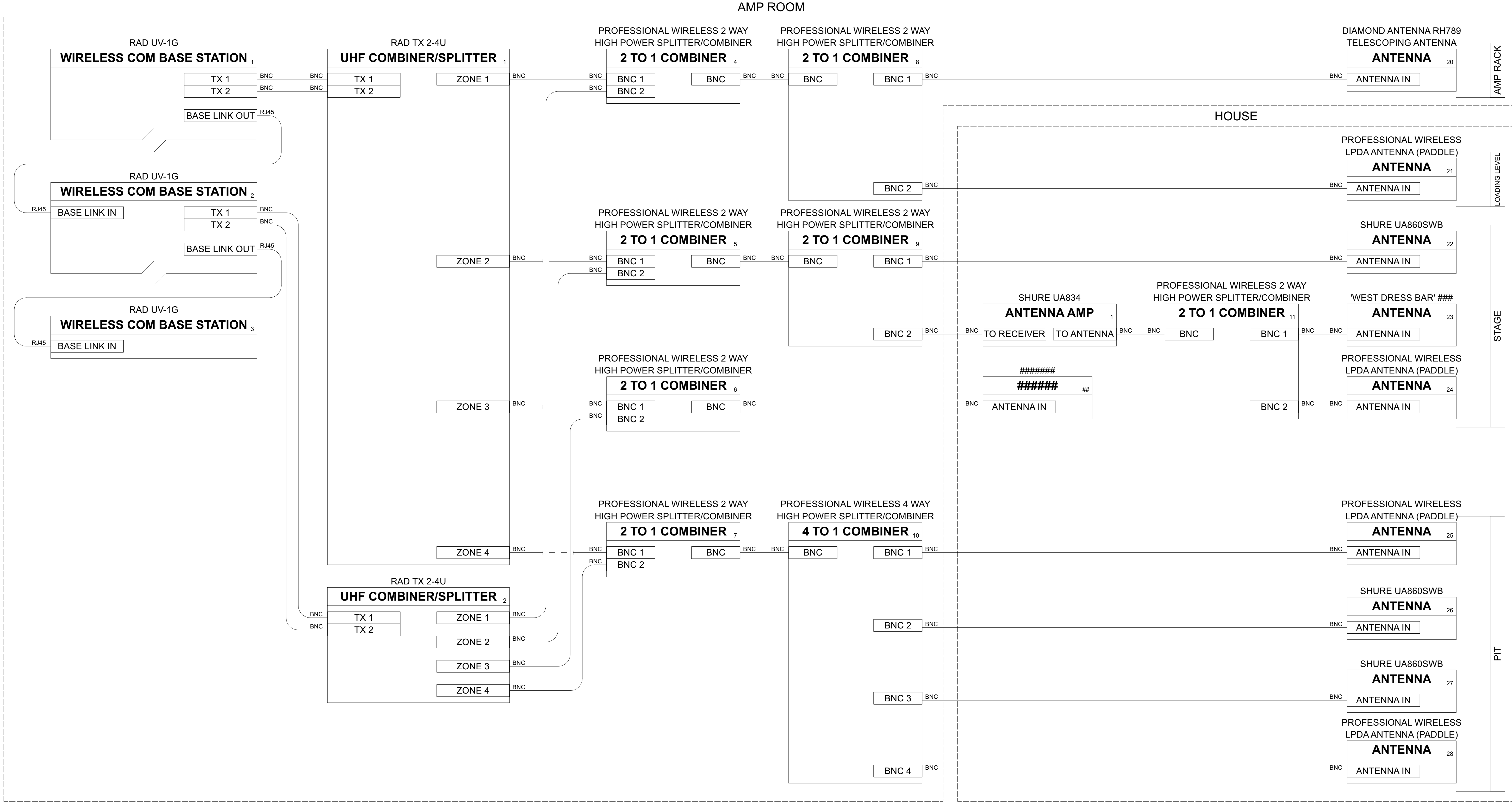



SHOW
SCHOOL OF ROCK

VENUE
YOUNG LIVING CENTRE STAGE

DEPARTMENT HEAD
MICHELLE OHUMUKINI
michelleo@hct.org

DRAFTED BY
MATTHEW KUPFERER

NOTES

TITLE
CONTROL NETWORK

SHEET
BLOCK DIAGRAM

22 / 29

LAST UPDATED
Nov 2, 2022 SCALE
NO SCALE

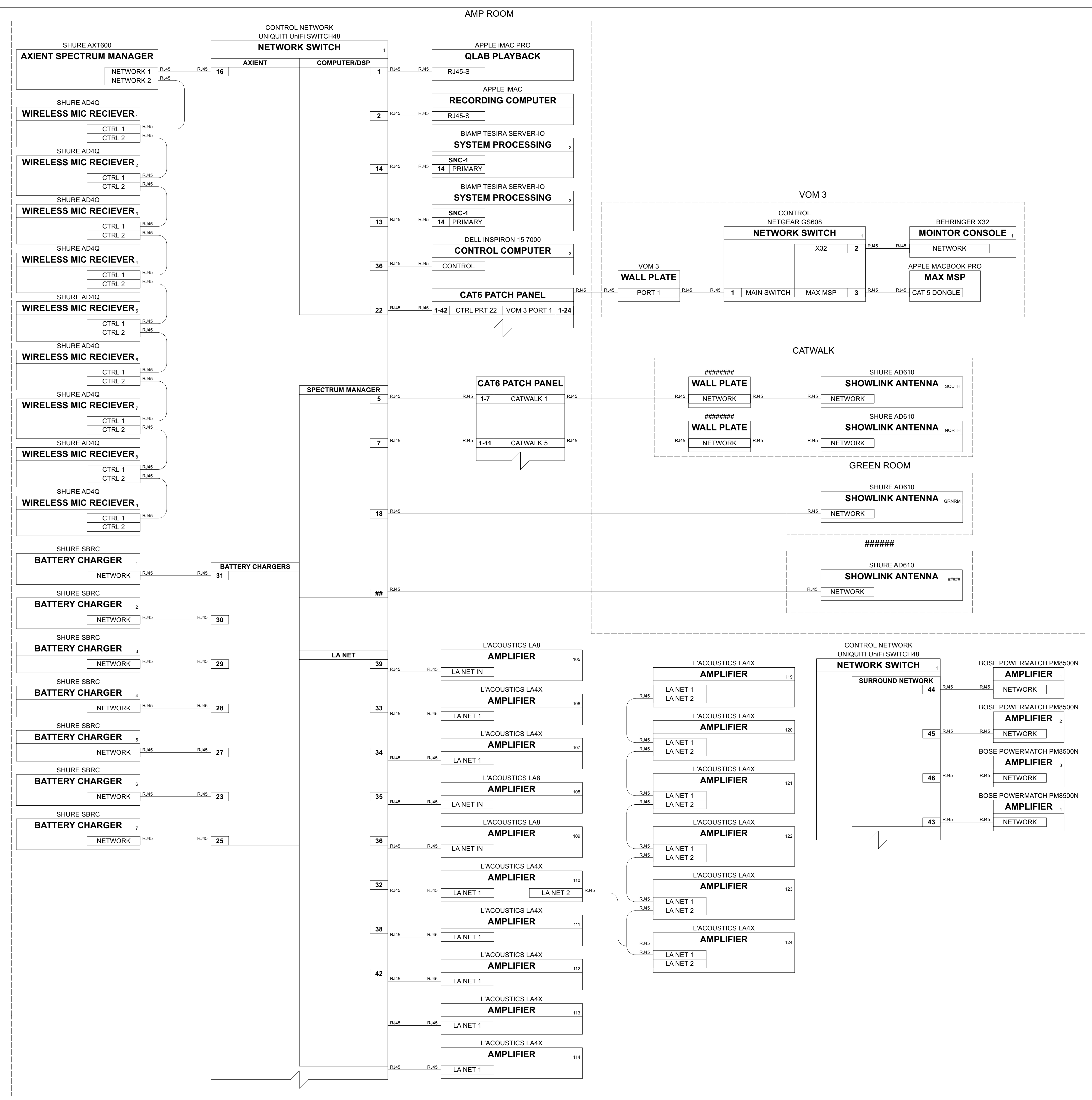

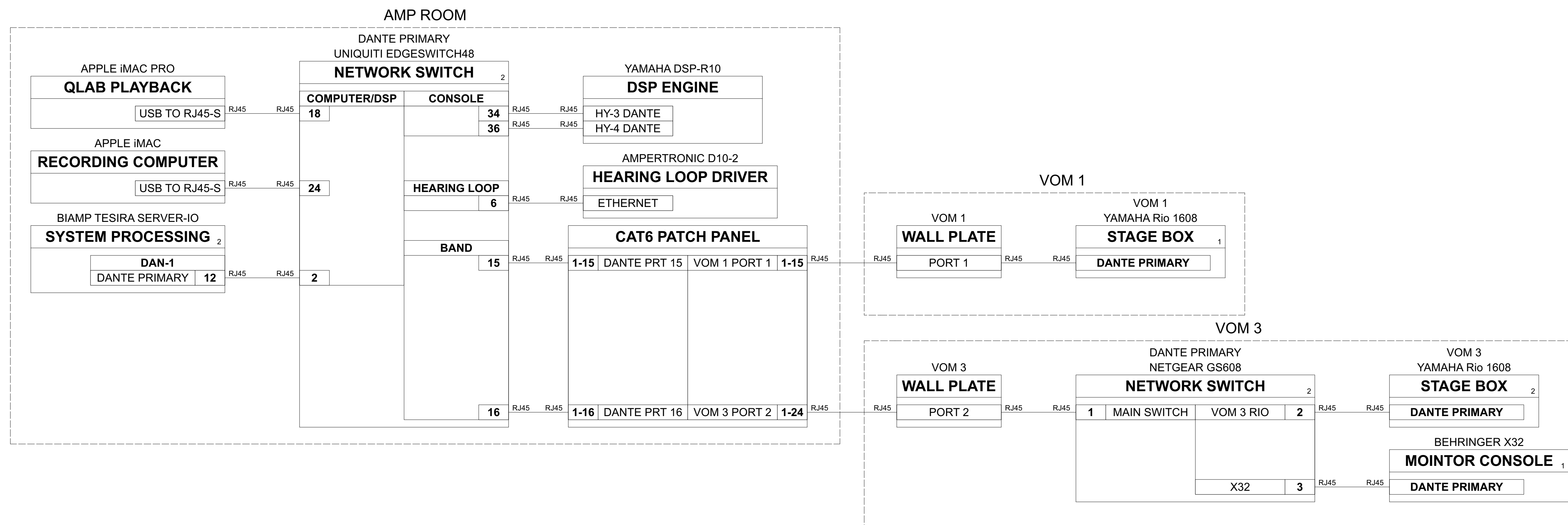



SHOW
SCHOOL OF ROCK

VENUE
YOUNG LIVING CENTRE STAGE

DEPARTMENT HEAD
MICHELLE OHUMUKINI
michelleo@hct.org

DRAFTED BY
MATTHEW KUPFERER

NOTES

TITLE
AVB NETWORK

SHEET BLOCK DIAGRAM

24 / 29

LAST UPDATED
Nov 2, 2022 SCALE
NO SCALE

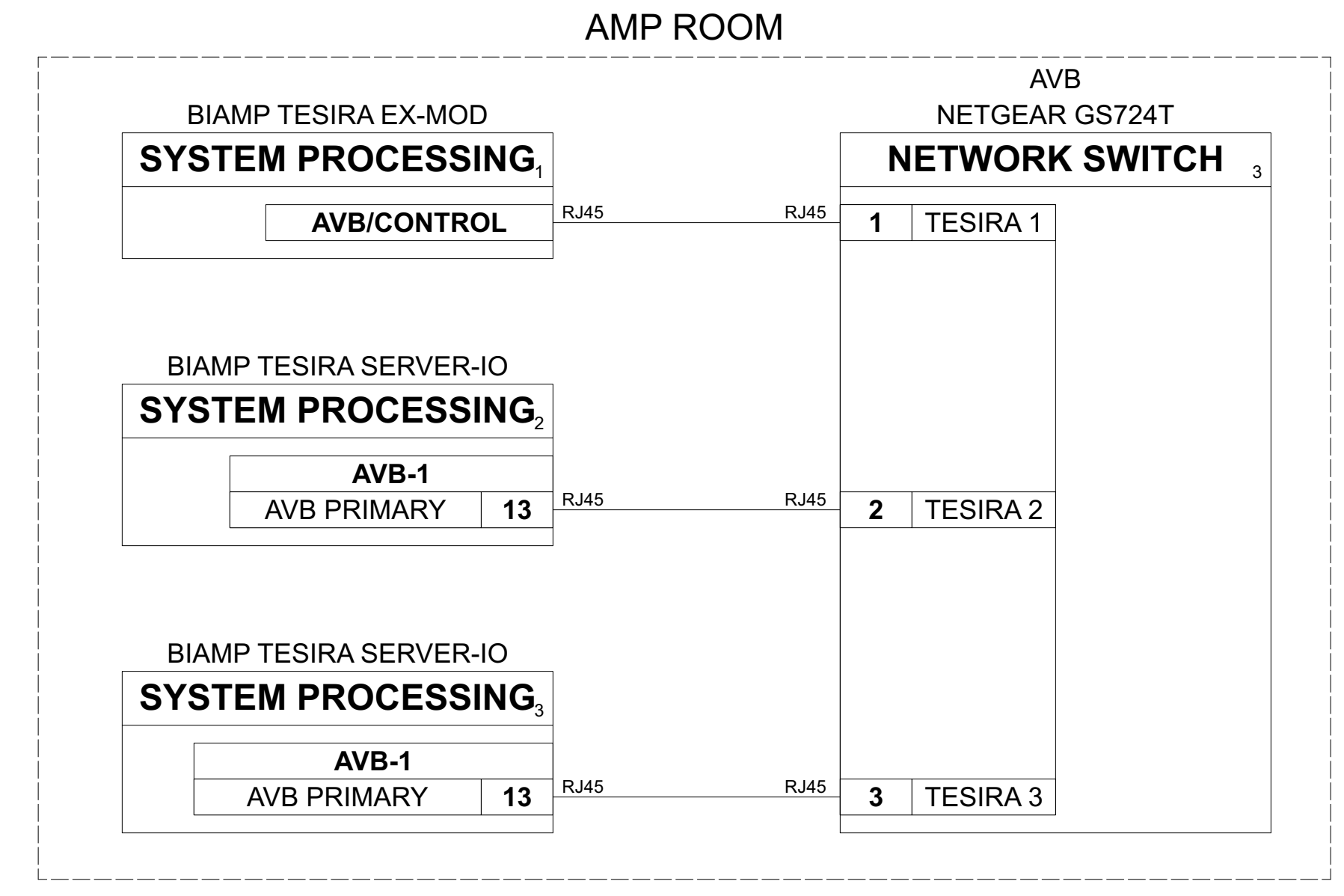



HALE CENTRE THEATRE

SHOW
**SCHOOL OF
ROCK**

VENUE
**YOUNG LIVING
CENTRE STAGE**

DEPARTMENT HEAD
MICHELLE OHUMUKINI
michelleo@hct.org

DRAFTED BY
MATTHEW KUPFERER

NOTES

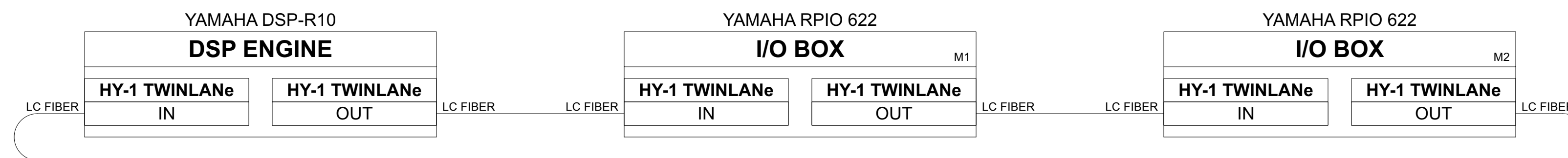

TITLE

TWINLANe

SHEET BLOCK DIAGRAM

25 / 29

LAST UPDATED **Nov 2, 2022** SCALE **NO SCALE**

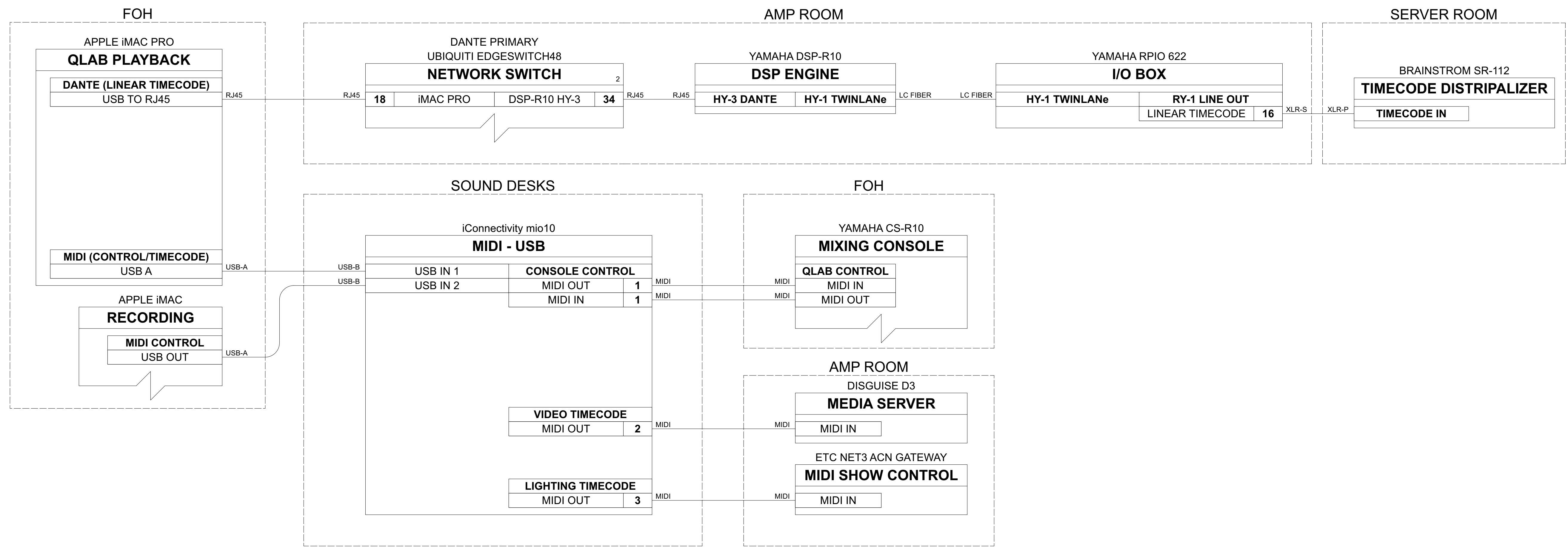

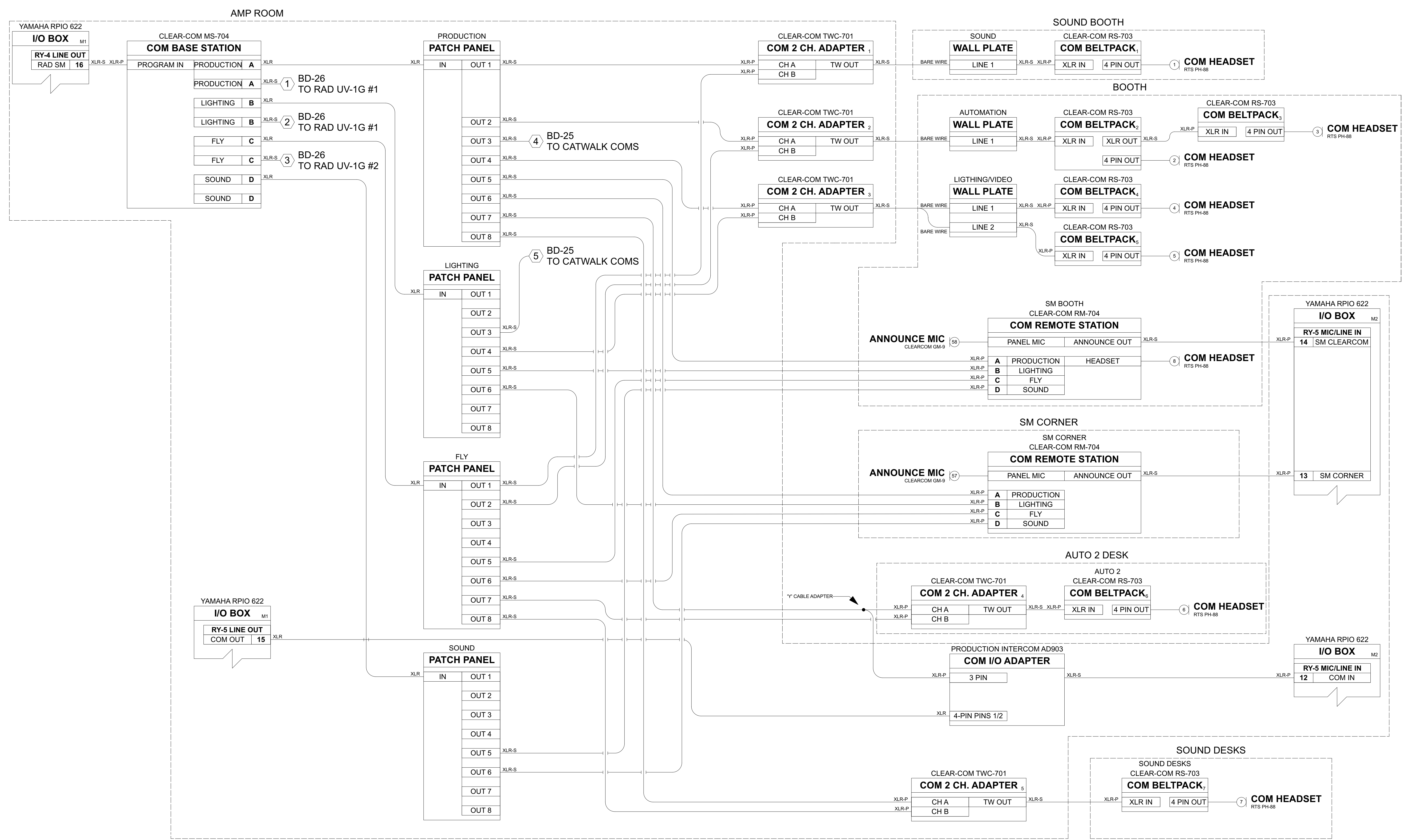

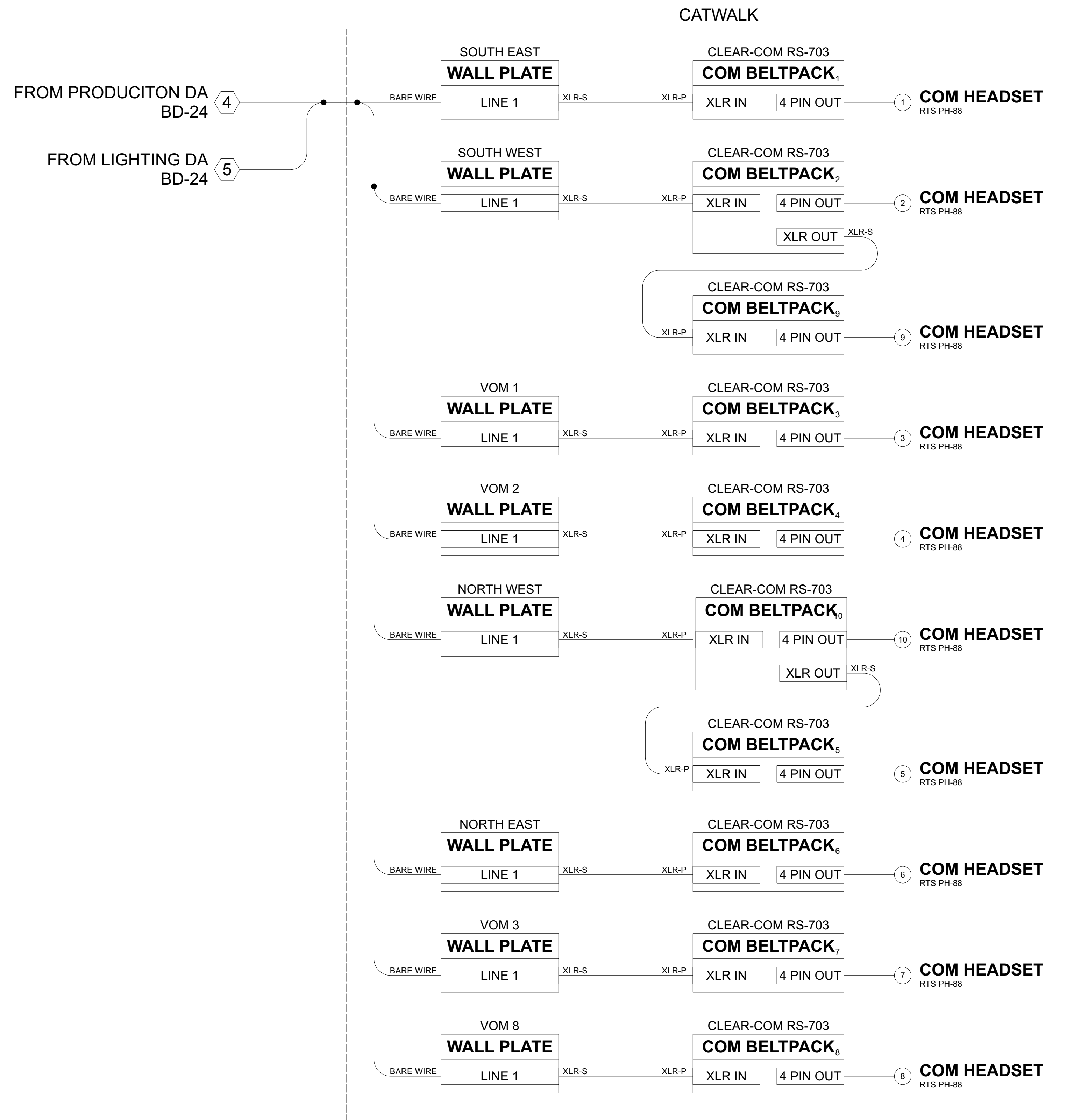

AMP ROOM

PRODUCTION/LIGHTING

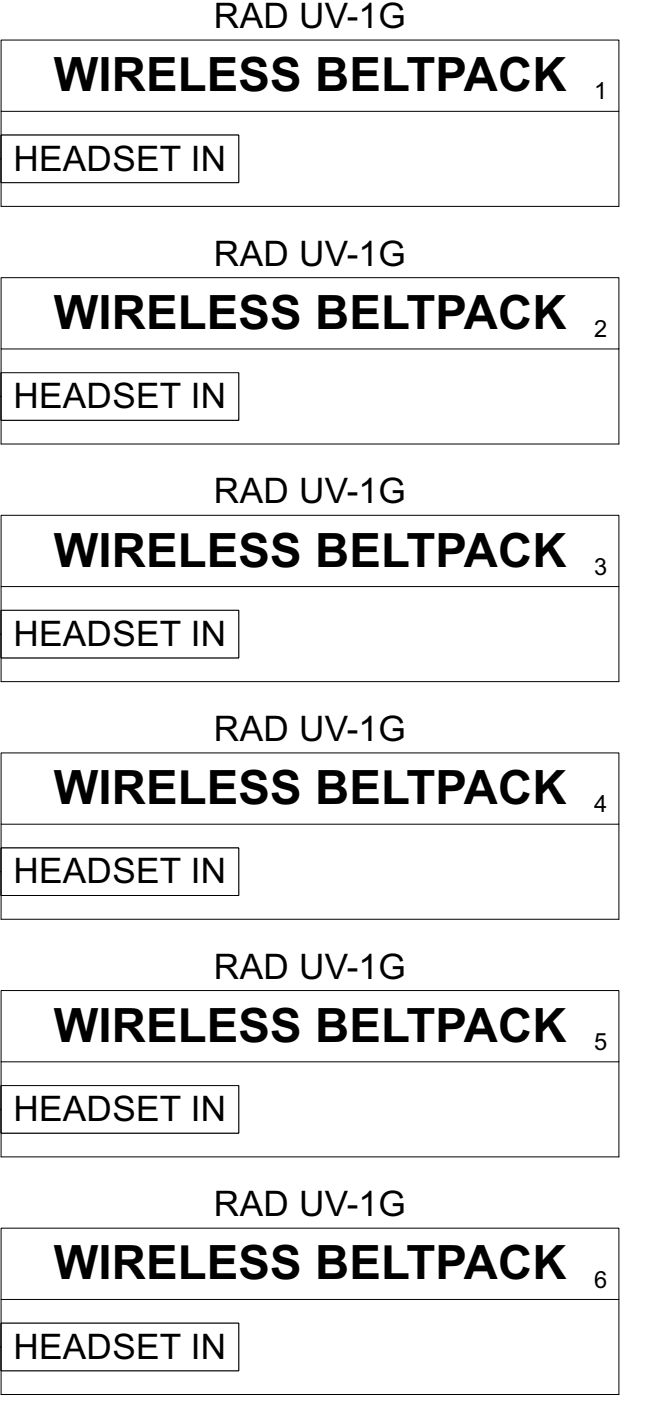

PRODUCTION/FLY



AMP ROOM

NOTE: SEE COM ANTENNA DISTRIBUTION (BD-20 TO BD-21) FOR ANTENNA INFORMATION

