

BYU THEATRE AND MEDIA ARTS DEPARTMENT	
LITTLE SHOW OF HORRORS	
AUDIO SIGNAL PATH	DWG. #
DIRECTOR: GEORGE NELSON	1
DESIGNER: MATTHEW KUPFERER	
EMAIL: MATTHEW.KUPFERER@GMAIL.COM	
AST. DESIGNER: GRANT PORTER	OF: 8
DRAFTER: GRANT PORTER	
EMAIL: GRANTPORTER@GMAIL.COM	
APPROVED:	SCALE: NO SCALE
	LAST REVISION DATE: 1/08/2020

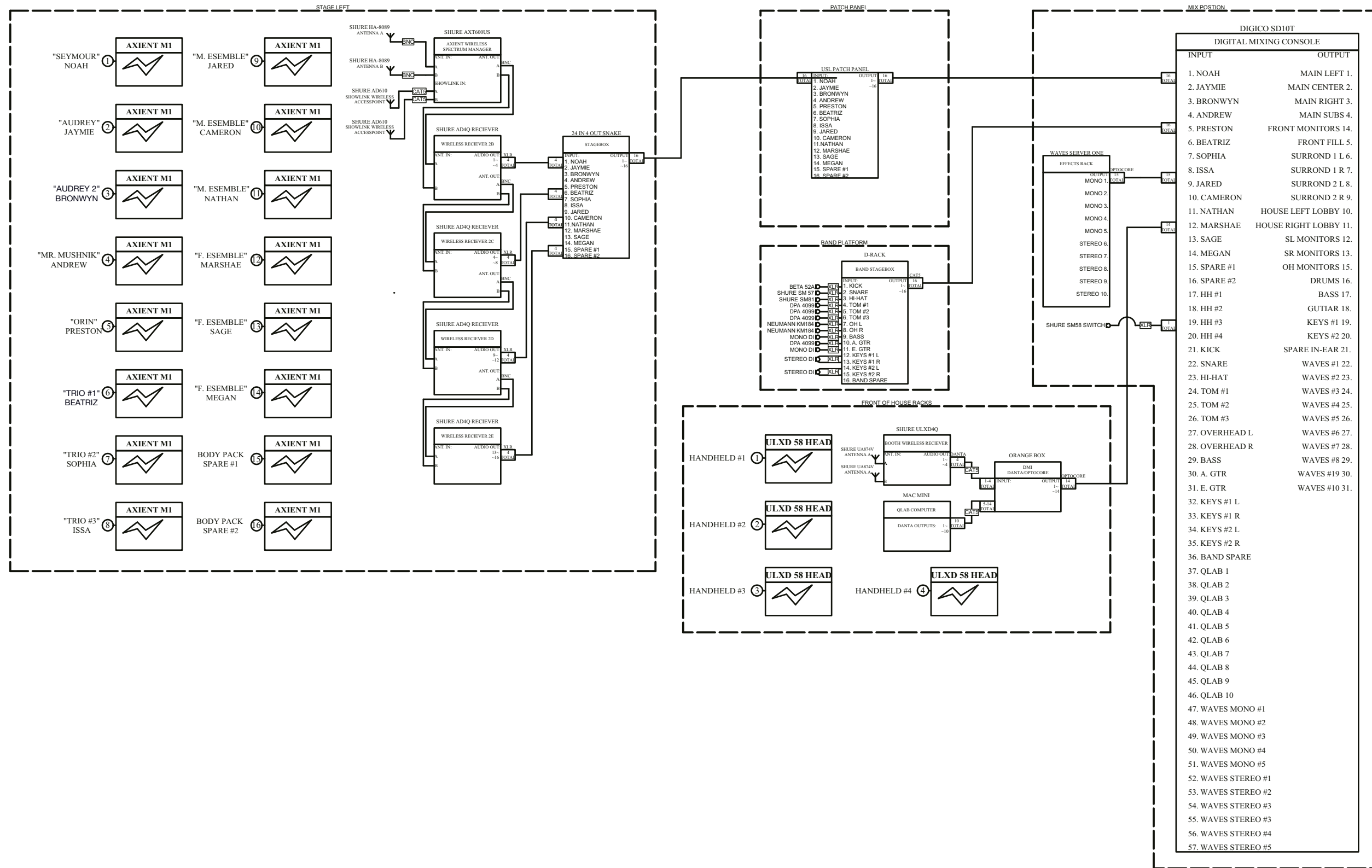

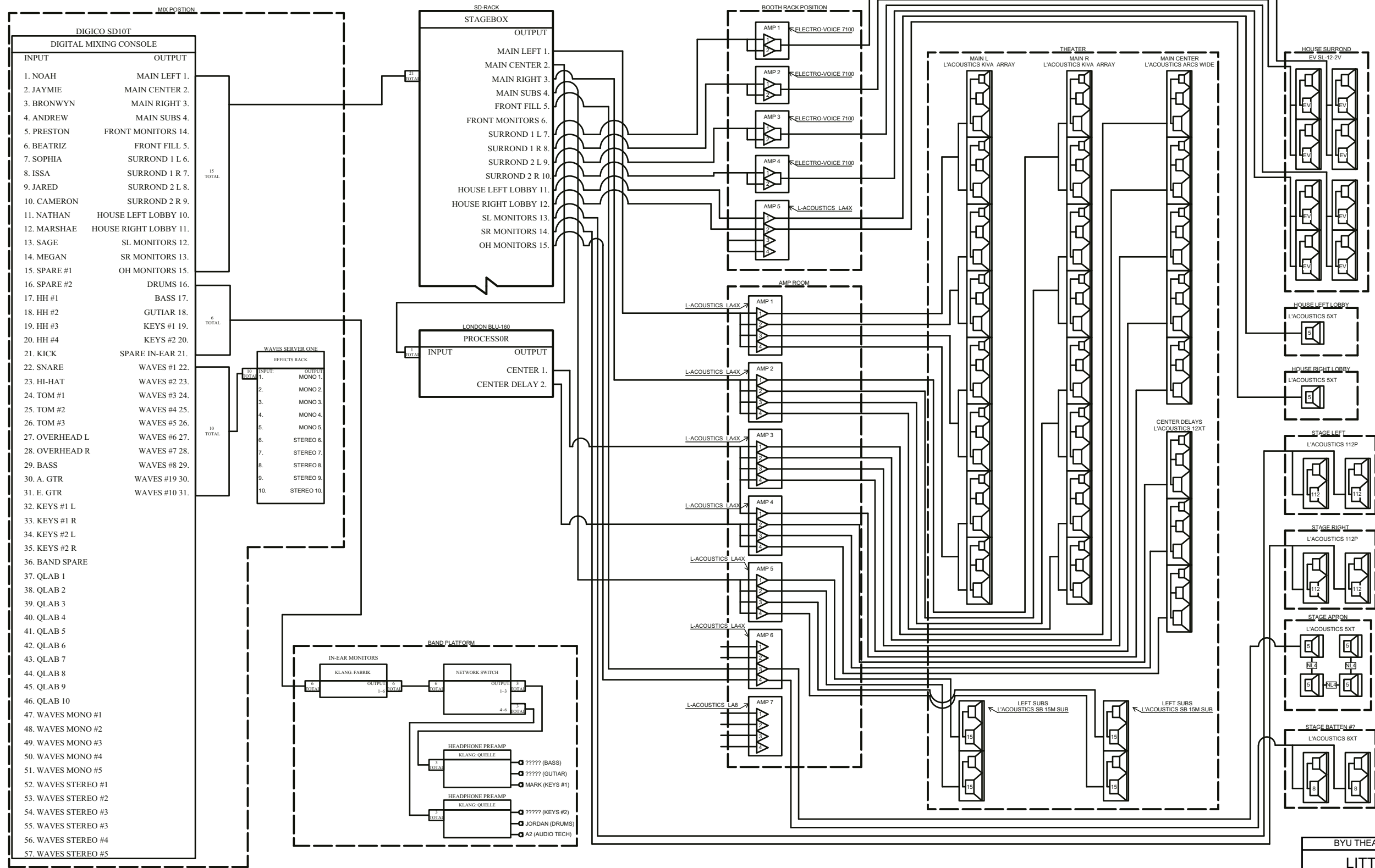



BYU THEATRE AND MEDIA ARTS DEPARTMENT	
LITTLE SHOW OF HORRORS	
AUDIO INPUT SIGNAL PATH	DWG. #
DIRECTOR: GEORGE NELSON	2
DESIGNER: MATTHEW KUPFERER	
EMAIL: MATTHEW.KUPFERER@GMAIL.COM	OF: 8
AST. DESIGNER: GRANT PORTER	
DRAFTER: GRANT PORTER	LAST REVISION
EMAIL: GRANTPORTER@GMAIL.COM	
APPROVED:	SCALE: NO SCALE
DATE: 1/08/2020	

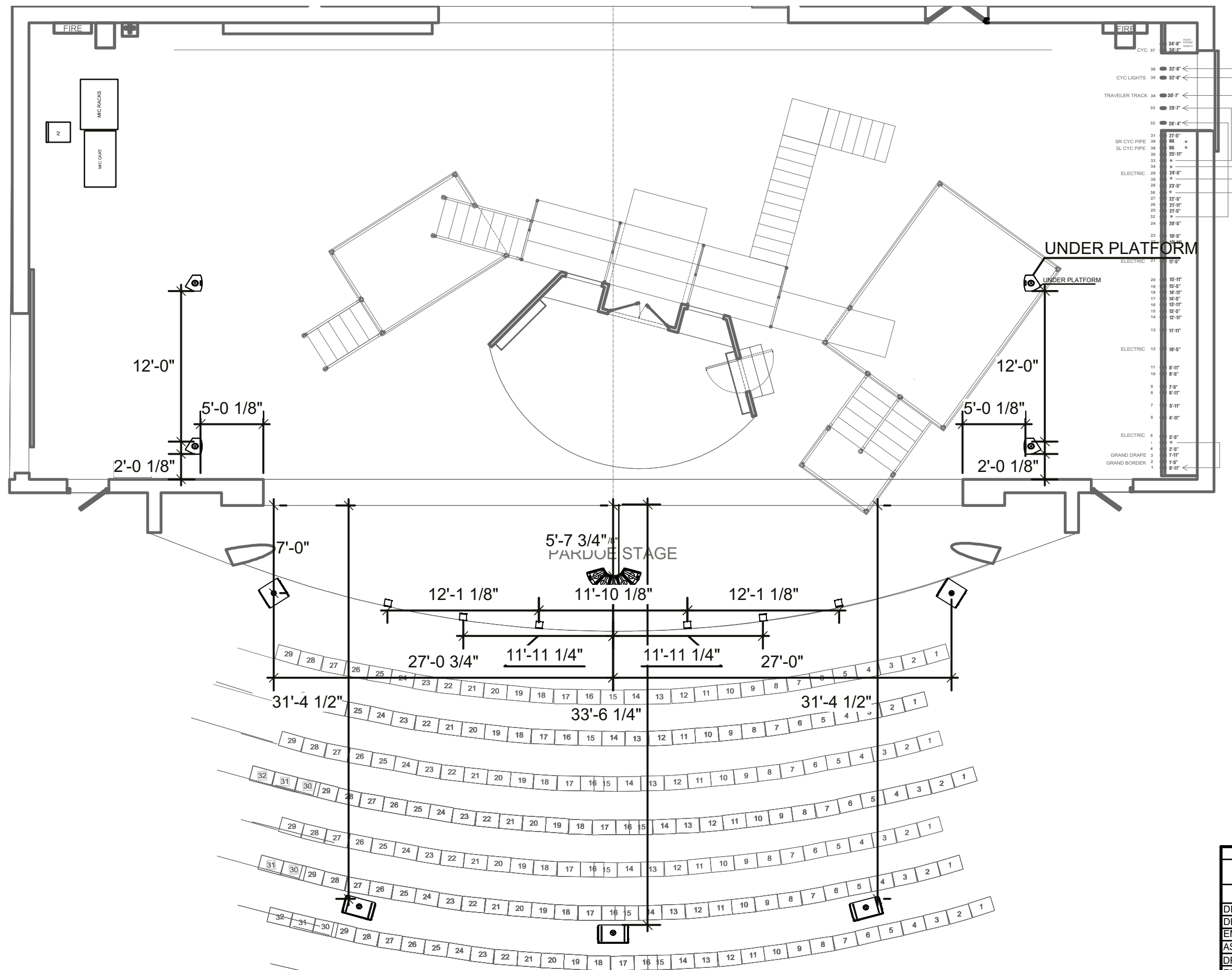

BYU THEATRE AND MEDIA ARTS DEPARTMENT	
LITTLE SHOW OF HORRORS	
AUDIO OUTPUT SIGNAL PATH	
DWG. #	
DIRECTOR: GEORGE NELSON	
DESIGNER: MATTHEW KUPFERER	
EMAIL: MATTHEW.KUPFERER@GMAIL.COM	
AST. DESIGNER: GRANT PORTER	
DRAFTER: GRANT PORTER	
EMAIL: GRANTPORTER@GMAIL.COM	
APPROVED:	SCALE: NO SCALE
LAST REVISION DATE: 1/08/2020	

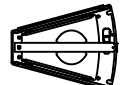
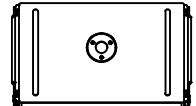

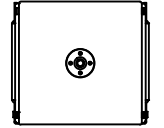

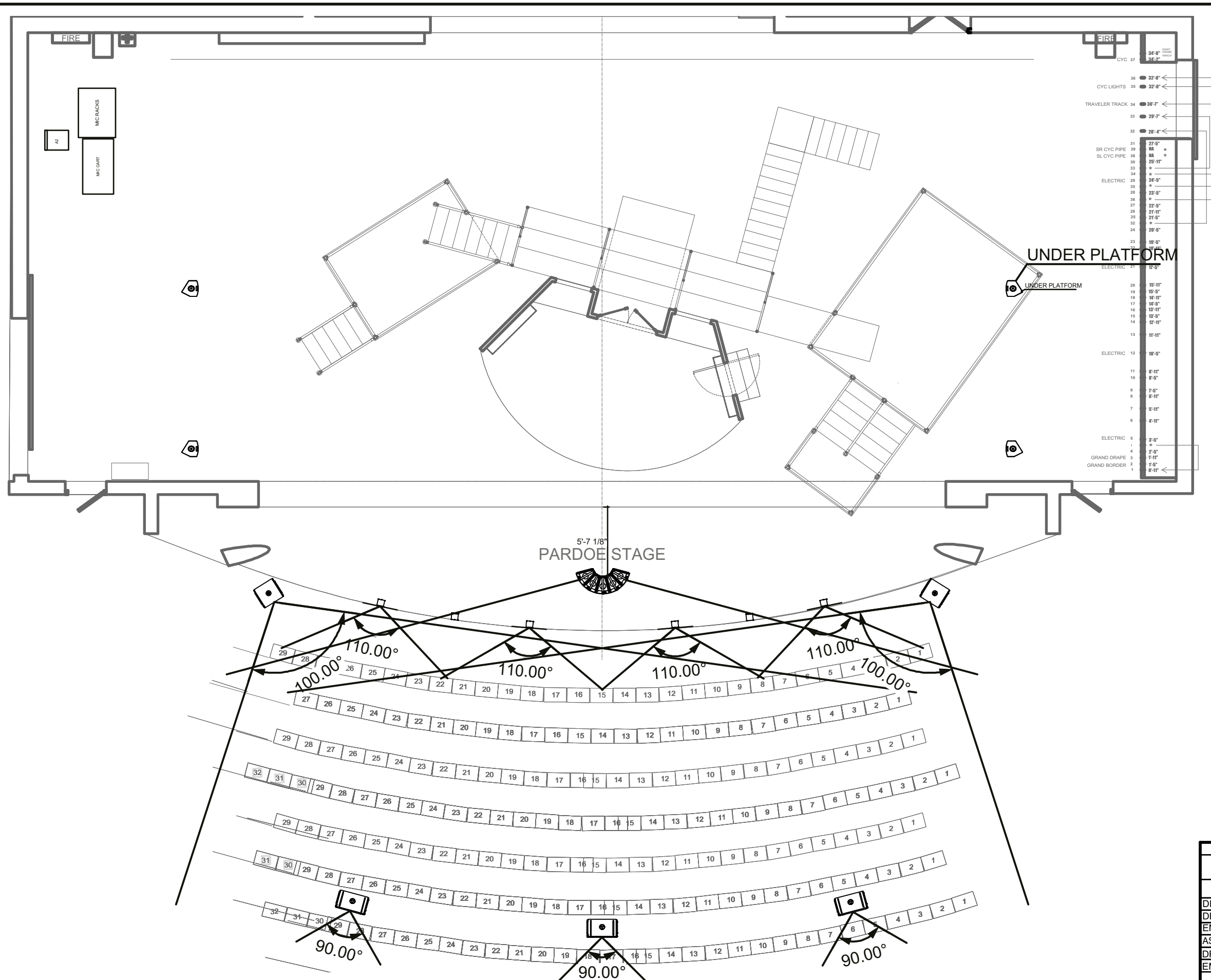

INSTRUMENT KEY

-  =L -ACOUSTICS ARCS WIDE
-  =L -ACOUSTICS ARCS WIDE
-  =L -ACOUSTICS KIVA
-  =L -ACOUSTICS SB15M
-  =L -ACOUSTICS 112P
-  =L -ACOUSTICS 5XT

BYU THEATRE AND MEDIA ARTS DEPARTMENT	
LITTLE SHOW OF HORRORS	
TOP VIEW SPEAKER PLOT	DWG. #
DIRECTOR: GEORGE NELSON	4
DESIGNER: MATTHEW KUPFERER	
EMAIL: MATTHEW.KUPFERER@GMAIL.COM	
AST. DESIGNER: GRANT PORTER	OF: 8
DRAFTER: GRANT PORTER	
EMAIL: GRANTPORTER@GMAIL.COM	LAST REVISION
APPROVED:	DATE: 1/08/2020
	SCALE: NO SCALE

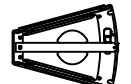

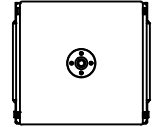
INSTRUMENT KEY

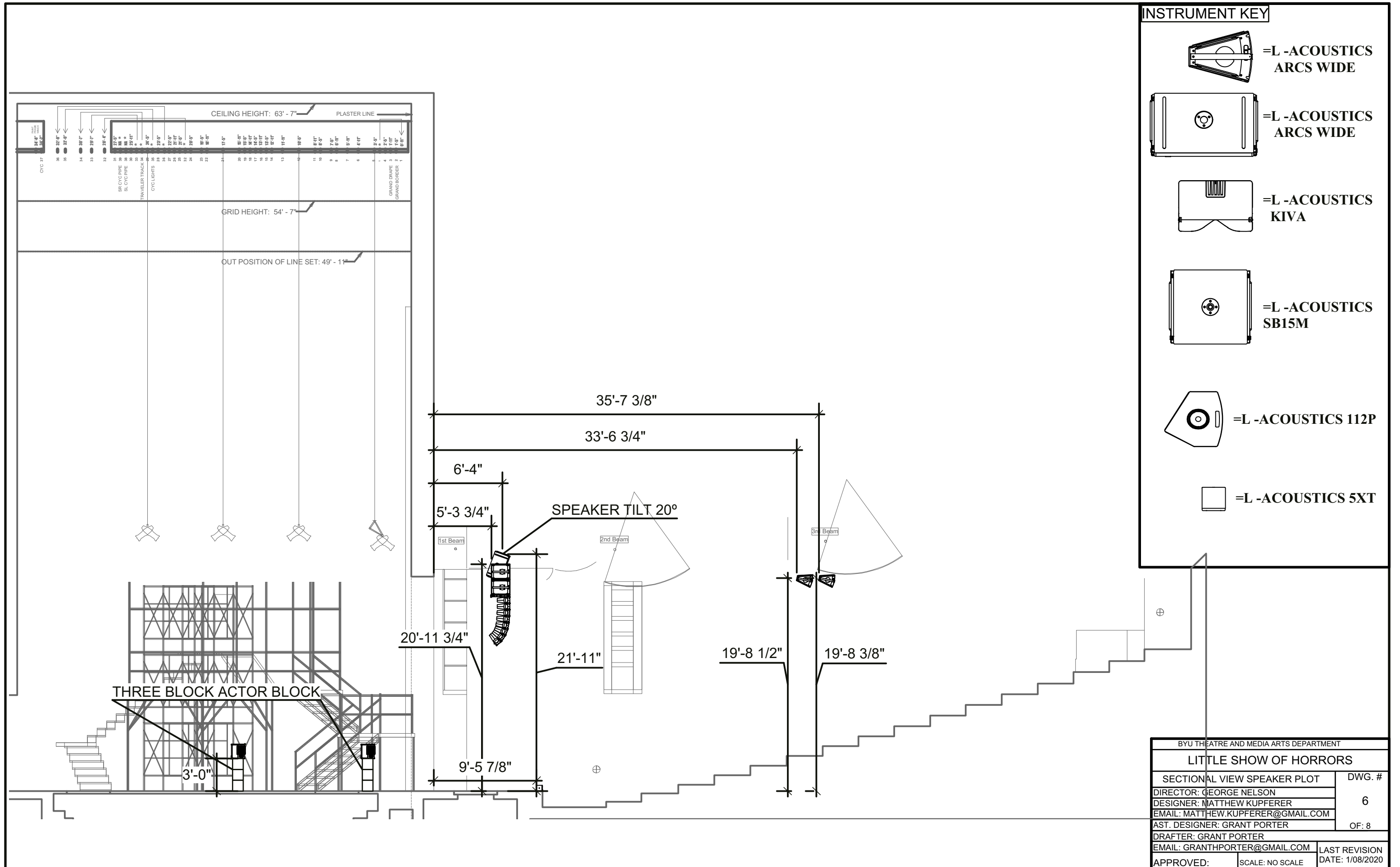

-  =L -ACOUSTICS ARCS WIDE
-  =L -ACOUSTICS ARCS WIDE
-  =L -ACOUSTICS KIVA
-  =L -ACOUSTICS SB15M
-  =L -ACOUSTICS 112P
-  =L -ACOUSTICS 5XT

BYU THEATRE AND MEDIA ARTS DEPARTMENT	
LITTLE SHOW OF HORRORS	
TOP VIEW SPEAKER COVERAGE	DWG. #
DIRECTOR: GEORGE NELSON	5
DESIGNER: MATTHEW KUPFERER	
EMAIL: MATTHEW.KUPFERER@GMAIL.COM	
AST. DESIGNER: GRANT PORTER	OF: 8
DRAFTER: GRANT PORTER	
EMAIL: GRANTPORTER@GMAIL.COM	LAST REVISION
APPROVED:	DATE: 1/08/2020
	SCALE: NO SCALE

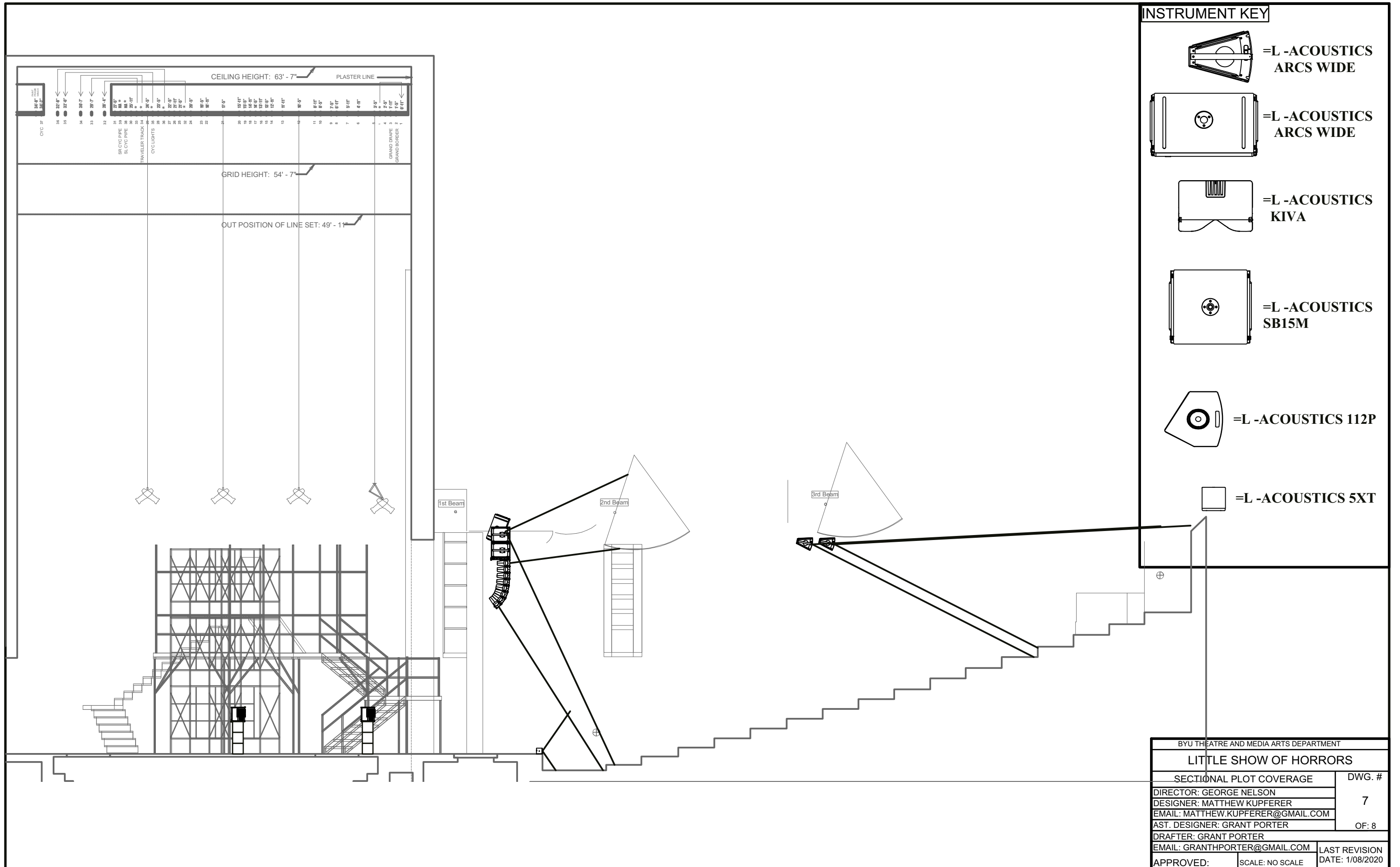

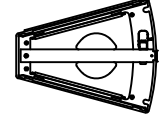
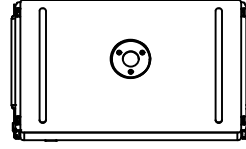
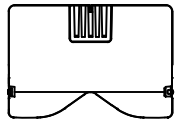
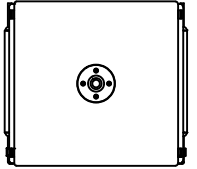
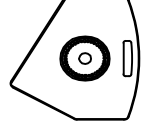

INSTRUMENT KEY

-  =L -ACOUSTICS ARCS WIDE
-  =L -ACOUSTICS ARCS WIDE
-  =L -ACOUSTICS KIVA
-  =L -ACOUSTICS SB15M
-  =L -ACOUSTICS 112P
-  =L -ACOUSTICS 5XT

BYU THEATRE AND MEDIA ARTS DEPARTMENT	
LITTLE SHOW OF HORRORS	
SECTIONAL PLOT COVERAGE	DWG. #
DIRECTOR: GEORGE NELSON	7
DESIGNER: MATTHEW KUPFERER	
EMAIL: MATTHEW.KUPFERER@GMAIL.COM	OF: 8
AST. DESIGNER: GRANT PORTER	
DRAFTER: GRANT PORTER	
EMAIL: GRANTPORTER@GMAIL.COM	LAST REVISION
APPROVED:	DATE: 1/08/2020
SCALE: NO SCALE	

